

# POWERSCREEN® TRAKPACTOR 550

HORIZONTAL IMPACTOR



TECHNICAL SPECIFICATION - REV 1.1 01/08/2019





## TRAKPACTOR 550



# OVERVIEW

### SPECIFICATION

<b>Total Weight PS:</b>	Tier 4F: 57,450kg (126,656lbs) Hopper extensions, bypass conveyor, single pole magnet
<b>Total Weight VGF:</b>	Tier 3: 54,850kg (120,924lbs) Hopper extensions, bypass conveyor, single pole magnet, extended main conveyor
<b>Transport</b>	<p><b>Length</b> 17.46m (57' 5") PS &amp; Standard product conveyor</p> <p><b>Height</b> 3.8m (12' 6")</p> <p><b>Width</b> 3m (9' 10")</p>
<b>Working</b>	<p><b>Length</b> 17.82m (58' 6") PS &amp; Standard product conveyor</p> <p><b>Height</b> 5.15m (16' 10")</p> <p><b>Width</b> 6.96m (22' 10")</p>
<b>Crusher Type:</b>	Twin apron 4 bar impact crusher, feed opening 1370mm x 911mm (54" x 36")
<b>Power Unit</b>	Tier 3 Caterpillar C13 328kW (440hp), Tier 4F Scania DC13 368kW (494hp) or Constant Speed Scania DC13 371kW (498hp)
<b>Plant Colour</b>	RAL 5021, RAL 7024, RAL 9005



### APPLICATIONS



#### Aggregate

Blasted rock  
River rock



#### Recycling

C&D waste  
Foundry waste



#### Mining

Processed ores  
Processed minerals



## TRAKPACTOR 550



# FEATURES & BENEFITS

The Powerscreen® Trakpactor 550 horizontal shaft impactor is designed for processing soft to medium-hard primary & secondary materials such as natural rock & construction derived materials like asphalt, recycling & demolition waste.

Material is fed into the large feed hopper, common on both vibrating grizzly feeder & live pre-screen versions, both feature a selectable crusher bypass facility & optional fines discharge conveyor. Load sensing, ensures the wide crusher inlet opening receives a continuous feed of pre-screened material, avoiding unnecessary crusher wear.

The Powerscreen® Trakpactor 550's robust impact chamber features a twin apron, 4 bar rotor design, with hydraulic release aprons, hydraulic setting adjustment, hydraulic crusher overload & is driven directly off the engine via clutch for optimum fuel economy. Next crushed material passes; either over the independent under pan feeder & modular product conveyor, or directly onto the full length conveyor, both conveyors feature a raise/lower facility to aid clearance of rebar in the event of a blockage.

The plant has been designed with ease of maintenance in mind, hydraulic banks, battery access and control valves are at eye level to make setup and operation much easier.

- Output potential of up to 500 tph / 550 US tph - depending on material type & crusher settings
- Suitable for a variety of feed materials, ideal for recycling, demolition & quarry applications
- Double deck grizzly feeder with underscreen
- Load management system to control feeder speed
- Proven impact crusher with hydraulic overload protection, 4 bar rotor & twin apron design
- Hydraulic inlet lid allows 'near-size' pieces to enter chamber without blocking inlet
- Hydraulic autoset CSS adjustment (optional on Terex chamber only)
- Heavy duty under crusher impact bars as standard
- Fully independent under crusher vibrating pan feeder (optional)
- Modular conveyor with raise/lower facility to aid clearance of rebar
- Bypass conveyor selection on either side of plant
- Chamber drive via clutch & highly fuel efficient direct drive system
- Crusher speed variation through user friendly PLC control system
- Live pre-screen (optional)



## TRAKPACTOR 550



# ↓ CRUSHER

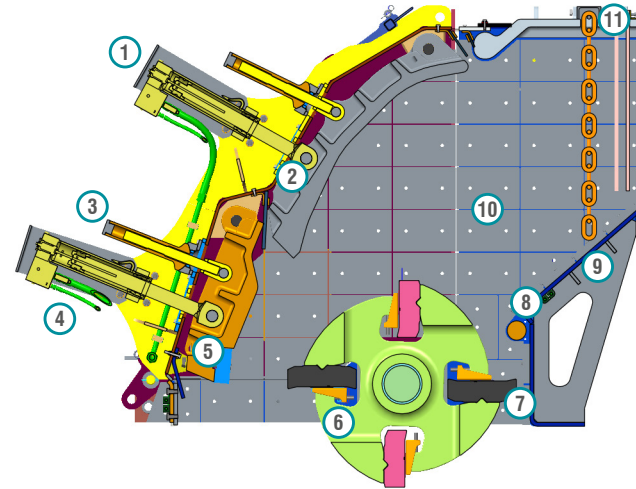

### PRINCIPAL COMPONENTS

- |   |                                 |
|---|---------------------------------|
| 1: Control Cylinder                                     | 7: Full Blow Bar                |
| 2: Top Impact Apron                                     | 8: Inlet Wear Beam              |
| 3: Apron Adjustment Spindle                             | 9: Inlet Plate                  |
| 4: Control Cylinder (Auto Adjust Apron Setting Control) | 10: Wear Liners                 |
| 5: Bottom Impact Apron                                  | 11: Crusher Hydraulic Inlet lid |
| 6: Rotor  |                                 |

### PRINCIPLES OF OPERATION

Material enters via crusher opening & slides down the inlet chute where it is struck by the blowbars fixed within the rotor. This initial impact breaks the material which is then accelerated towards the top apron where more reduction takes place on impact. This material then falls back onto the blowbars & the cycle is repeated until the material is small enough to pass between the top apron & blowbar. Further reduction occurs on the bottom apron until the material can again pass

through the gap & discharge from the underside of the crusher.

Should an un-crushable object enter the chamber, the overload cylinders will relieve & allow the object to pass. The cylinders will then return to the pre-set crushing position. The pre-set gap is adjusted by turning the adjustment spindle whilst the weight of the apron is held on the cylinder (hydraulic assist).

The hydraulic cylinders are pre-loaded to minimise apron bounce & wear on the cylinders. This arrangement also greatly reduces the oversize produced & is Patented: GB2455203



## TRAKPACTOR 550



# CRUSHER SPECIFICATION

<b>Feed opening:</b>	1370mm x 911mm (54" x 36")
<b>Max lump size*:</b>	500mm <sup>3</sup> (20in <sup>3</sup> ) / 860mm (34") diagonally /1000 x 1000 x 200mm (39 x 39 x 8") slab (blasted rock (limestone type): 600 x 600 x 600mm) *depending on material & blow bar specification
<b>Rotor width:</b>	1330mm (52")
<b>Rotor diameter:</b>	1210mm (47")
<b>Number of aprons:</b>	2
<b>Max clearance:</b>	Top apron: 265mm (10.5") Bottom apron: 305mm (12")
<b>Max OSS setting:</b>	200mm (7.9") upper apron, 200mm (7.9") lower apron
<b>Min CSS setting:</b>	35mm (1.4") upper apron, 20mm (0.8") lower apron
<b>Blow bars:</b>	Total of 4 blow bars
<b>Blow bar removal:</b>	Vertically
<b>Blow bar configuration:</b>	2 full & 2 half (optional 4 full)
<b>Setting adjustment:</b>	Auto adjust / hydraulic assist
<b>Overload protection:</b>	Hydraulic
<b>Rotor speeds:</b>	537 - 694rpm (34 - 44m/s) (111 - 144ft/s)
<b>Applications:</b>	Demolition / recycling / quarry
<b>Crusher weight:</b>	14540kg (32,055lbs)
<b>Full blow bar weight:</b>	410kg (904lbs)
<b>Side liners:</b>	20mm (thick abrasion resistant steel)

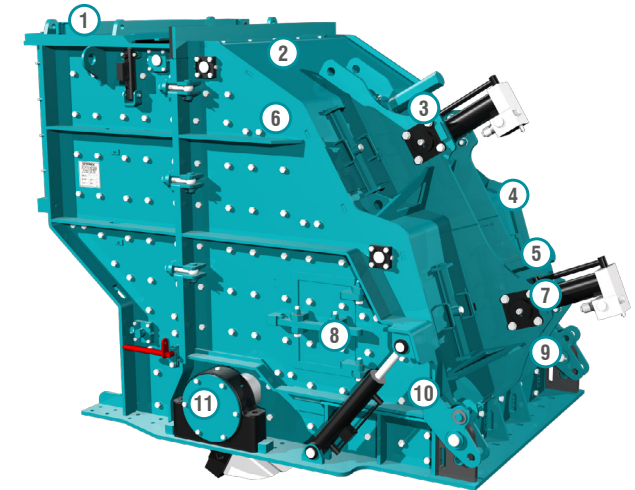

### PRINCIPAL COMPONENTS

- 1: Hydraulic inlet lid
- 2: Main welded body
- 3: Impactor hinged section
- 4: Inspector covers
- 5: Hydraulic overload & adjustment cylinders
- 6: Toggle bolts
- 7: Inspection covers
- 8: Side door
- 9: Trunions
- 10: Hinged section opening cylinder
- 11: Bearings



## TRAKPACTOR 550



# CRUSHER FEATURES

- Crusher body:** Fabricated from steel plate & fully lined with replaceable abrasion resistant liner plates. Hinged side door allows access to apron tips & rotor for gap measurements & inspection. Complete hinged section opens hydraulically to allow blow bar removal & replacement, apron & liner replacement or major maintenance
- Rotor:** Cast steel & fitted with 4 reversible & replaceable blow bars
- Bearings:** Double row self aligning spherical roller bearing fitted each end of rotor
- Aprons:** Cast steel aprons with replaceable abrasion resistant wear plate on tip of bottom apron
- Drive:** Direct through wedge belts with tensioning system on the power unit
- Lubrication:** Rotor bearings are greased & fitted with inner & outer labyrinth seals
- Blow bars:** Standard blow bar is martensitic steel, options are available in martensitic ceramic, medium chrome, medium chrome ceramic, high chrome, high chrome ceramic & toughened chrome

## APPLICATIONS

This plant is designed for both demolition & quarrying applications. When fitted with martensitic or ceramic blow bars the crusher will tolerate small quantities of steel reinforcing bar in the feed. However, the machine is not designed to accept large pieces (maximum 20mm diameter, 500mm long) of steel or other uncrushable objects, & the feed material should be assessed / inspected for suitability prior to crushing. It is vitally important that large pieces of steel or similar un-crushable objects are not allowed to enter the crushing chamber as severe damage & injury may occur.

When high chrome bars are fitted, all steel should be removed from the feed material & the machine should only be used on quarry applications, or clean materials such as asphalt.

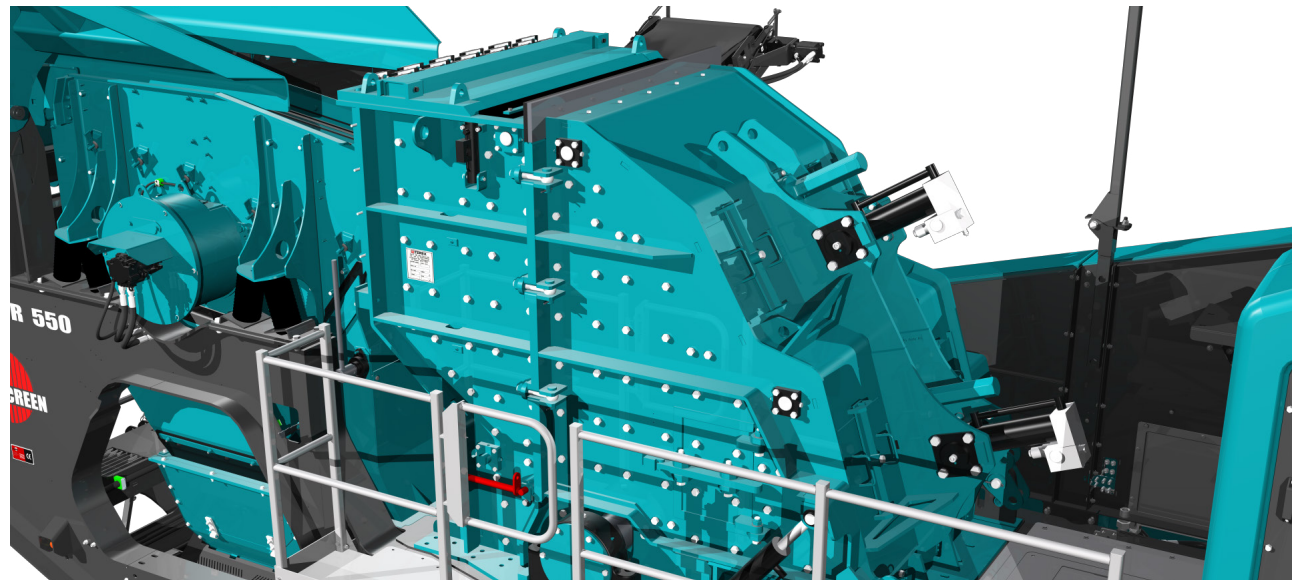



## TRAKPACTOR 550



# ↓ HOPPER

Hydraulic folding hopper with over centre struts & wedge-lock system

- Loading length:** 4.23m (13' 11")
- Hopper width:** 2.71m (8' 11")
- Hopper capacity:** 7m<sup>3</sup> (9.2 cu. yd.)
- Hopper body:** 12mm thick abrasion resistant steel plate

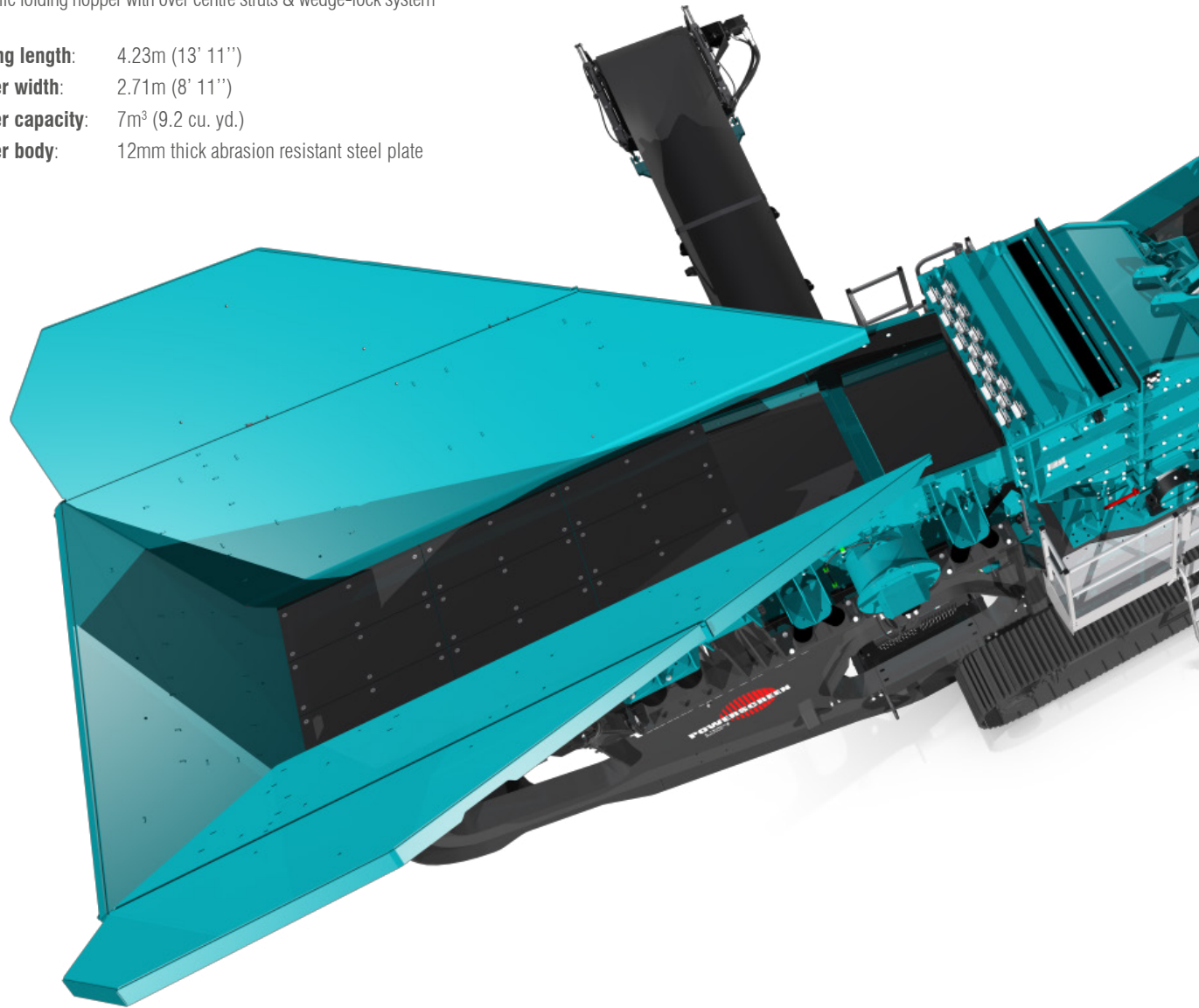



## TRAKPACTOR 550



# VIBRATING GRIZZLY FEEDER

<b>Type:</b>	Spring mounted vibrating	<b>Mesh:</b>	Blanking mat standard, underscreen mesh available in 10mm (0.4"), 20mm (0.8"), 30mm (1.2"), 40mm (1.6") & 50mm (2")
<b>Vibrating unit:</b>	Twin heavy duty cast eccentric shafts running in spherical roller bearings. Gears coupled at drive end	<b>Punch plate:</b>	Available in 30mm (1.2"), 38mm (1.5"), 50mm (2"), 60mm (2.4"), 63mm (2.5") & 75mm (3")
<b>Length:</b>	4.06m (13' 4")	<b>Chute:</b>	Plant is fitted with a bypass chute, with an internal two way flap door to control direction of fines, either forward onto the product belt or down onto the optional bypass conveyor (if blanking mat is fitted)
<b>Width:</b>	1.27m (4' 2")		
<b>Pan:</b>	12mm (0.5") thick abrasion resistant steel base plate liners		
<b>Drive:</b>	Flange mounted hydraulic motor		
<b>Grizzly:</b>	2m (6' 7") long double section of welded tapered finger bars at 34mm (1.33") as standard or 38mm (1.5"), 50mm (2"), 60mm (2.4"), 63mm (2.5") & 75mm (3") optional nominal spacing fabricated in 20mm thick abrasion resistant steel		

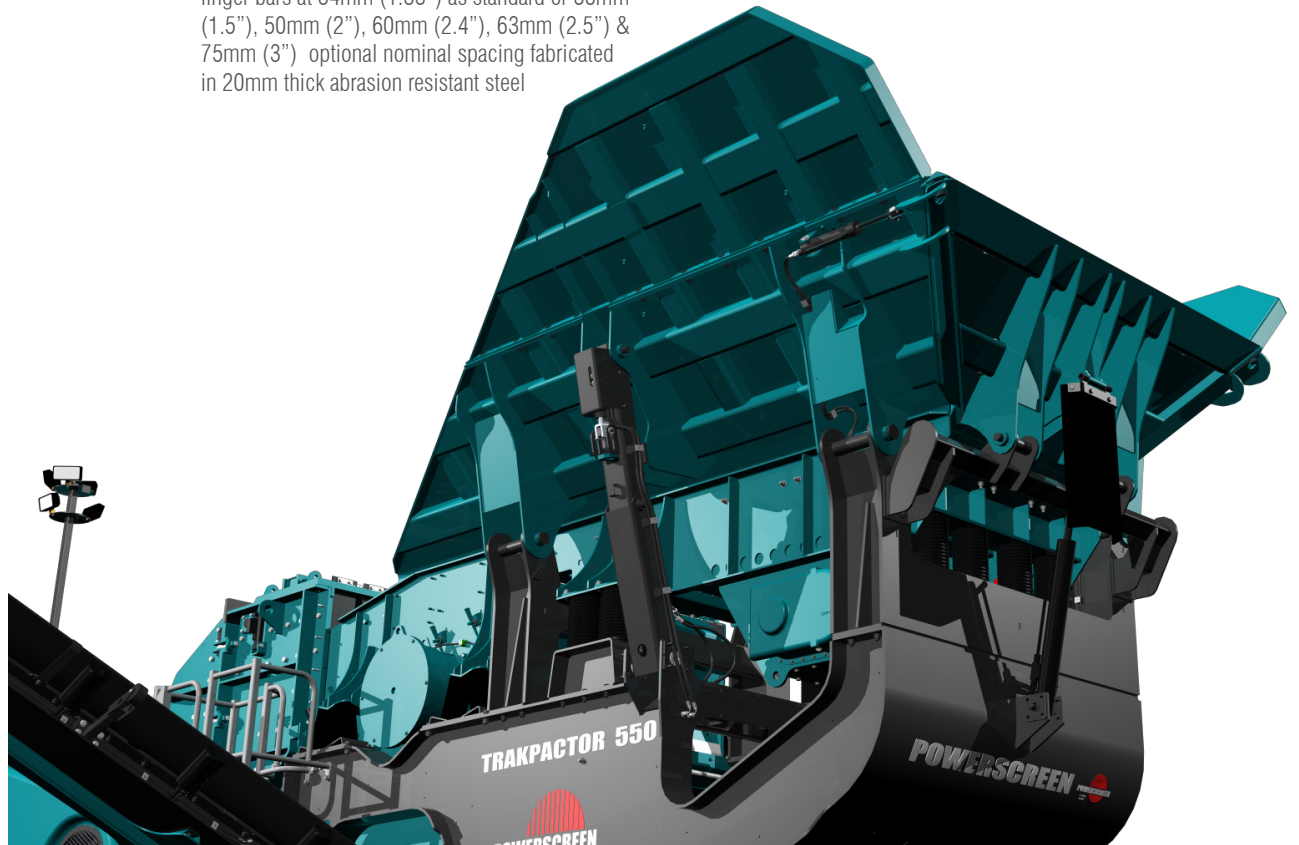



## TRAKPACTOR 550



# ↓ PRODUCT CONVEYOR

<b>Conveyor type:</b>	Fully removable modular unit with hydraulic raise & lower facility to increase clearance & simplify rebar removal. Shallow troughed with winged rollers & fully tunnelled with minimal snag areas
<b>Belt type:</b>	Ripstop EP500/3 8+2 with steel wire breaker ply
<b>Belt width:</b>	1200mm (3' 11")
<b>Discharge height:</b>	3.8m (12' 6") when fully raised
<b>Stockpile volume:</b>	101m <sup>3</sup> (132 cu. yd.)
<b>Feedboot:</b>	Fabricated steel with abrasion resistant steel liners
<b>Impact area:</b>	Heavy duty under crusher impact bars
<b>Skirting:</b>	Fully skirted in wear resistant rubber up to magnet discharge area
<b>Drive:</b>	Dual hydraulic motor direct to head drum
<b>Lubrication:</b>	Centralised grease points for lubrication of shaft bearings
<b>Belt covers:</b>	Optional aluminium removable dust covers
<b>Belt adjustment:</b>	Belt tensioning is by use of screw adjustment at

	the head drum
<b>Speed wheel:</b>	Designed to stop plant feed if the discharge conveyor slows or stops

### DUST SUPPRESSION SYSTEM

Spray bars with atomiser nozzles mounted over product conveyor & final conveyor discharge, piped to an inlet manifold for customer water supply or optional pump.

<b>Type:</b>	Clean water multi atomising nozzles
<b>Inlet:</b>	Single point on chassis
<b>Inlet pressure:</b>	3 bar (44psi)
<b>Water supply:</b>	24 litres (6.3 g) per minute min
<b>Frost protection:</b>	Via system main valves
<b>Pump:</b>	Optional





## TRAKPACTOR 550



# POWER UNIT & HYDRAULICS

<b>Tier 3 Equivalent:</b>	Caterpillar C-13 ACERT, 6 cylinder, 328 kW (440hp)
<b>Operating Conditions:</b>	Ambient temp. +30°C to -5°C (86°F to 23°F) at altitudes up to 2000m (6562ft) above sea level - For applications outside this range please consult with Powerscreen as the plant performance / reliability may be affected.
<b>Operating rpm range:</b>	1700 - 2100rpm
<b>Emission control technique:</b>	Not applicable
<b>Plant drive:</b>	High quality tandem pumps driven via engine PTO's
<b>Clutch type:</b>	DESCH REVOX 14" WET CLUTCH
<b>Tier 4F / Stage IV:</b>	Scania DC13 385A - 368kW (494hp)
<b>Operating conditions:</b>	Ambient temp. +30°C to -5°C (86°F to 23°F) at altitudes up to 2000m (6562ft) above sea level - For applications outside this range please consult with Powerscreen as the plant performance / reliability may be affected
<b>Operating rpm range:</b>	1500 - 1900rpm
<b>Typical fuel composition:</b>	N/A
<b>Emission control technique:</b>	Selective Catalytic Reduction (SCR)
<b>Reductant tank size:</b>	60 L (16 US Gal)
<b>Plant drive:</b>	High quality pumps driven via clutch PTO's
<b>Clutch type:</b>	DESCH REVOX 14" WET CLUTCH
<b>Constant speed stage IIIA (EU Only):</b>	Scania DC13 371kW (498hp)
<b>Operating Conditions:</b>	Ambient temp. +30°C to -5°C (86°F to 23°F) at altitudes up to 2000m (6562ft) above sea level - For applications outside this range please consult with Powerscreen as the plant performance / reliability may be affected

<b>Emission control technique:</b>	Not applicable
<b>Reductant tank size:</b>	60 L (16 US Gal)
<b>Plant drive:</b>	High quality pumps driven via clutch PTO's
<b>Clutch type:</b>	DESCH REVOX 14" WET CLUTCH
<b>Fuel tank capacity:</b>	1000 L (264 US Gal)
<b>Hydraulic tank capacity:</b>	740 L (195 US Gal)
<b>Crusher drive:</b>	Direct drive via wedge belts, clutch pulley diameter 425mm T4, 375mm T3 Crusher pulley diameter 800mm Terex (39") 800mm with Hazemag chamber Crushing performance can be tuned, by changing engine speed via the PLC .
<b>Crusher drive tensioning:</b>	VEE belt tensioner system

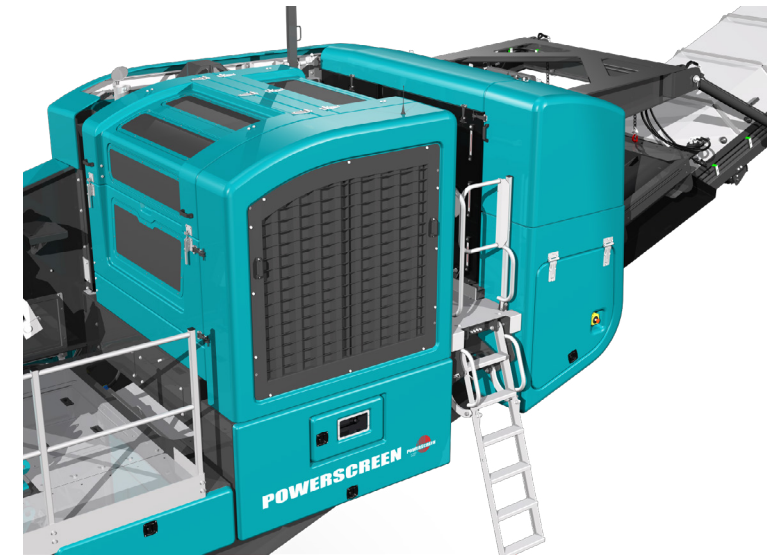



## TRAKPACTOR 550



# ↓ TRACKS

### TRACKS

<b>Type:</b>	Heavy duty tracks, bolted to chassis on pads & pins
<b>Sprocket centres:</b>	3.72m (12' 2")
<b>Track width:</b>	500mm (1' 8")
<b>Gradeability:</b>	30° maximum
<b>High speed:</b>	1.19kph (0.74 mph)
<b>Drive:</b>	Two integral hydraulic motors
<b>Tensioning:</b>	Hydraulic adjuster, grease tensioned





## TRAKPACTOR 550



# PLANT CONTROLS & OTHER

## GUARDS

Wire mesh, sheet metal or GRP guards are provided for all drives, flywheels, pulleys & couplings.

The guards provided are designed & manufactured to CE & ANSI standards.

## PLATFORMS

Platforms are provided for maintenance on both sides of the feeder & impactor, these are fitted with double row handrails & access ladders. Platforms are also provided to gain access to the rear of the crusher on the pre-screen model & power unit.

## CHASSIS

Heavy duty I-section of welded construction provides maximum strength & accessibility

## PLANT CONTROLS

Full PLC control system

Full colour backlit screen

Complete pictorial user controls

Multi-function backlit menu buttons

Full system diagnostics

Sequential auto start up

Main controls

- Engine/crusher speed
- Feeder (start/stop/speed)
- Product conveyor + pan feeder (start/stop)
- Product conveyor raise/lower
- Side conveyor
- Crusher control/screen setup

## UMBILICAL CONTROL

An umbilical control unit is supplied with the plant. This is used to control the tracking function & is also fitted with a stop button for the plant.



## TRAKPACTOR 550



# **HAZEMAG IMPACT CRUSHER**



### PRINCIPAL COMPONENT

- |                             |                                 |
|-----------------------------|---------------------------------|
| 1: Control Cylinder         | 7: Full Blow bar                |
| 2: Top Impact Apron         | 8: Inlet Plate Control cylinder |
| 3: Apron Adjustment Spindle | 9: Inlet Wear Beam              |
| 4: Control Cylinder         | 10: Inlet Plate                 |
| 5: Bottom Impact Apron      | 11: Wear Liners                 |
| 6: Rotor                    | 12: Crusher Opening             |

### PRINCIPLES OF OPERATION

Material enters via the crusher opening & slides down the inlet chute where it is struck by the blow bar which is held within the rotor. This initial impact breaks the material which is then accelerated onto the top apron where more reduction takes place on impact. This material then falls back into the blow bars & the cycle repeated until the material is small enough to pass between the apron & the blow bar. Once through this gap, further reduction occurs on the bottom apron until the material

can again pass through the gap & discharge from the underside of the crusher.

Any un-crushable material entering the chamber will relieve the overload cylinders & allow the material to pass. The cylinders will then return to the pre-set crushing position. The pre-set gap is adjusted by turning the adjustment spindle whilst the weight of the apron is held on the cylinder (hydraulic assist)



## TRAKPACTOR 550



# HAZEMAG CRUSHER SPECIFICATION

<b>Feed opening:</b>	1360mm x 800mm (54" x 32")	<b>Number of blow bars:</b>	4
<b>Max lump size*:</b>	500mm <sup>3</sup> (20in <sup>3</sup> ) / 860mm (34") diagonally/ 1000 x 1000 x 200mm (39 x 39 x 8") slab *depending on material blow bar specification	<b>Blow bar removal:</b>	Vertically
<b>Rotor width:</b>	1340mm (53")	<b>Blow bar configuration:</b>	2 full & 2 half (optional 4 full)
<b>Rotor diameter:</b>	1200mm (47")	<b>Setting adjustment:</b>	Hydraulic assist
<b>Number of aprons:</b>	2	<b>Overload protection:</b>	Hydraulic
<b>Maximum clearance:</b>	273mm (11") on both aprons	<b>Rotor speeds:</b>	540 - 630rpm (34 - 40m/s) (111 - 131ft/s)
<b>Maximum OSS setting:</b>	200mm (8") upper apron, 100mm (4") lower apron	<b>Applications:</b>	Demolition / recycling / quarry
<b>Minimum CSS setting:</b>	75mm (3") upper apron, 35mm (1.4") lower apron	<b>Crusher weight:</b>	14,855kg (32,750lbs)
		<b>Full blow bar weight:</b>	410kg (904lbs)
		<b>Side Liners:</b>	20mm thick, abrasive resistant steel



## TRAKPACTOR 550



# HAZEMAG CRUSHER FEATURES

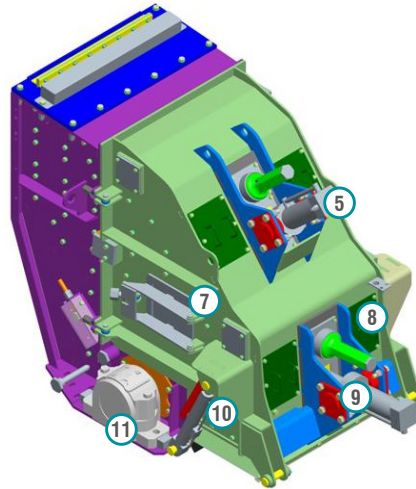

### PRINCIPAL COMPONENTS

- 1: Chain curtain cover
- 2: Main welded body
- 3: Impactor hinged section
- 4: Inspection covers
- 5: Hydraulic overload & adjustment cylinders
- 6: Toggle bolts
- 7: Side door
- 8: Inspection covers
- 9: Trunions
- 10: Hinged section opening cylinders
- 11: Bearings

### CRUSHER FEATURES

- Crusher body:** Fabricated from steel plate & fully lined with replaceable abrasion resistant liner plates. Hinged side door allows access to apron tips & rotor for gap measurements & inspection. Complete hinged section opens hydraulically to allow blow bar removal & replacement, apron & liner replacement or major maintenance
- Rotor:** Cast steel & fitted with 4 reversible & replaceable blow bars
- Bearings:** Double row self aligning spherical roller bearing fitted each end of rotor
- Aprons:** Cast steel aprons with replaceable abrasion resistant wear plate on tip of bottom apron
- Drive:** Direct through wedge belts with tensioning system on the power unit
- Lubrication:** Rotor bearings are greased & fitted with inner & outer labyrinth seals
- Blow bars:** Standard blow bar is martensitic steel, options available in high chrome & ceramic

### APPLICATIONS

This plant is designed for both demolition & quarrying applications. When fitted with martensitic or ceramic blow bars the crusher will tolerate small quantities of steel reinforcing bar in the feed. However, the machine is not designed to accept large pieces of steel or other uncrushable objects, & the feed material should be assessed / inspected for suitability prior to crushing. It is vitally important that large pieces of steel or similar uncrushable objects are not allowed to enter the crushing chamber as severe damage & injury may occur.

When high chrome bars are fitted, all steel should be removed from the feed material & the machine should only be used on quarry applications, or clean materials such as asphalt.



## TRAKPACTOR 550



# ↓ OPTIONS

### BYPASS CONVEYOR

<b>Conveyor type:</b>	Troughed EP400/3 4+2 covers hydraulically folding
<b>Width:</b>	800mm (2' 7")
<b>Discharge height:</b>	3.2m (10' 6")
<b>Stockpile volume:</b>	60m <sup>3</sup> (78 cu. yd.)
<b>Drive:</b>	Direct hydraulic motor
<b>Lubrication:</b>	Centralised grease points for lubrication of shaft bearings
<b>Position:</b>	RHS or LHS

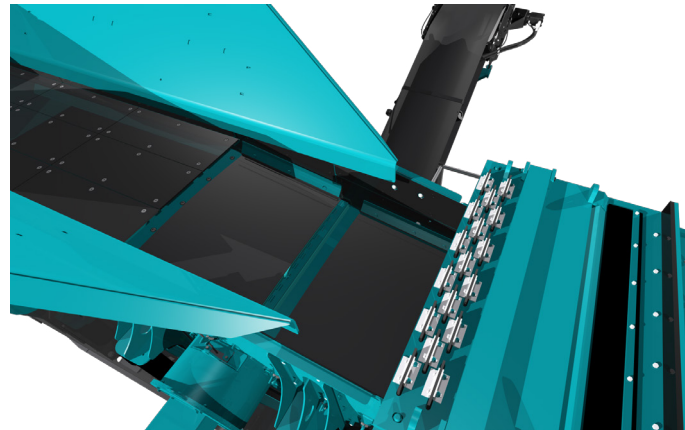

### PAN FEEDER & LIVE PRE-SCREEN

Vibrating pan feeder with 2 deck live pre-screen

<b>Pan type:</b>	Spring mounted vibrating pan
<b>Vibrating unit:</b>	Twin heavy duty cast eccentric shafts running in spherical roller bearings, gear coupled at drive end, flange mounted hydraulic motor
<b>Dimension length:</b>	2.9m (9' 6")
<b>Dimension width:</b>	1.2m (3' 11")
<b>Pan:</b>	15mm thick fully welded base plate with 12 mm thick abrasion resistant liners
<b>Pre-screen:</b>	Spring mounted vibrating unit with stepped finger bofor deck
<b>Vibrating unit:</b>	Single shaft, out of balance weights, flange mounted hydraulic motor
<b>Top deck dimension:</b>	
<b>Length:</b>	2.1m (6' 11")
<b>Width:</b>	1.27m (4' 2")
<b>Bofor deck:</b>	2 stepped bolt in cartridges with 1m (39") long self cleaning fingers 50mm (2") nominal spacing as standard.
<b>Control:</b>	Variable speed control though control panel & (radio remote optional)
<b>Chute:</b>	Bypass chute with internal 2 way flap door fitted, to control direction of fines, either forward onto the product belt or onto the optional side conveyor (if blanking mat is fitted)
<b>Bottom deck dimension:</b>	
<b>Length:</b>	1.6m (5' 3")
<b>Width:</b>	1.27m (4' 2")



## TRAKPACTOR 550



## OPTIONS 2

### HOPPER EXTENSIONS

<b>Hopper width:</b>	3.96m (13')
<b>Hopper capacity:</b>	11m <sup>3</sup> (14.4 cu. yd.)
<b>Body:</b>	10mm thick abrasion resistant steel plate

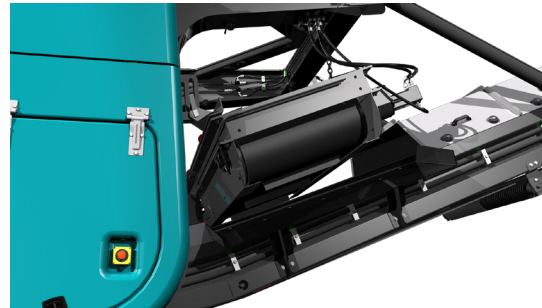

### SINGLE POLE & TWIN POLE MAGNETS

<b>Magnet type:</b>	Suspended self cleaning over band with endless belt
<b>Magnet block:</b>	836 x 530mm (33" x 21")
<b>Drive:</b>	Direct drive hydraulic motor
<b>Control:</b>	Pre-set variable speed
<b>Discharge:</b>	Via stainless steel shedder plate

### EXTENDED PRODUCT CONVEYOR

Hydraulically folding for transport

<b>Discharge height:</b>	4.2m (13' 9")
<b>Stockpile volume:</b>	137m <sup>3</sup> (179 cu. yd.)

### BLOW BARS

Standard blow bars supplied with plant are 2 high & 2 half martensitic steel. 2 further options are available:

<b>High chrome:</b>	Suitable for medium to hard rock applications where no steel is present in the feed material. Good wear characteristics
<b>Ceramic:</b>	Suitable for applications with limited steel in feed. Improved wear characteristics over standard martensitic blow bars
<b>4 full blow bars:</b>	Available in all options

### MECHANICAL BELT WEIGHER

Mechanical belt scale, monitors material volume as it passes onto product conveyor.

### FUEL ACTIVE DELIVERY SYSTEM

The FuelActive® fuel delivery system works by using a float to track the level of fuel in the tank. Drawing fuel from the upper limit of the fuel ensures that the throughput of water and contaminants is reduced by more than 300%, allowing the equipment to run for longer periods.

- Reduces emissions
- Preserves engine performance
- Improves Fuel Economy

### ELECTRIC REFUELLING PUMP

A refuelling pump, allows fuel to be drawn from a remote source. Fuel transfer rate of 50 L/min (13 G/min)

### RADIO REMOTE CONTROL

Complete with integrated tracking functions & plant stop button.

NB: Only available in certain countries where type approval has been obtained

Remote can also be used to:

- Feeder (start/stop/speed)
- Product conveyor (raise/lower)
- Open top apron



## TRAKPACTOR 550



# ↓ OPTIONS 3

### VIBRATING UNDERPAN FEEDER

- Type:** Steel bodied vibrating feeder fitted with stainless steel liners, mounted under the crusher & designed to prevent any impact damage to the product conveyor
- Width:** 1.42m (4' 8")
- Length:** 2.59m (8' 6")
- Drive:** Twin hydraulic driven out of balance vibrator units
- Note:** When a vibrating underpan feeder is selected, the short product conveyor belt which accompanies will have the following spec: EP500/4 8+2

### HOT/COLD CLIMATE OILS

Cold climate oils  
(Recommended for ambient temperatures between -20 to +30°C) - Hydraulic & lubrication oils only. Other component modifications may be required for low temperature operations. Please contact the Powerscreen sales & applications department with any queries.

Hot climate oils  
(Recommended for ambient temperatures between +15 to +50°C)

### CONTROL PANEL POSITIVE PRESSURISATION

An additional unit designed to reduce dust particles within the control panel.  
A continuous flow of clean air is passed through the cabinet whilst the unit simultaneously filters out any particulate laden air.

### OTHER OPTIONS

- Hazemag chamber

- 2 deck live pre-screen
- Grizzly decks 50mm, 63mm & 75mm
- Punch plates cartridges 38mm, 50mm, 63mm & 75mm
- Pre-screen meshes 25mm - 75mm (1" - 3")
- High chrome blow bars
- Ceramic blow bars
- 4 full size blow bars in lieu of 2 full 2 half blow bars
- Heavy duty underpan feeder
- Auto adjust bottom apron (Terex chamber only)
- Reversible fan
- Folding product conveyor (4.2m stockpile height)
- Left or right hand bypass conveyor
- Single pole or twin pole overband magnets
- Plant lighting
- Radio remote control
- Electric refuelling pump
- Mechanical belt weigher
- Hydraulic water pump for dust suppression
- Hot/Cold climate oils
- Hopper extensions (11m<sup>3</sup>)
- Fuel Active delivery system
- Control panel positive pressurisation
- Dust suppression system
- Slow speed pulley for reduced speed (Terex chamber only)



## TRAKTRACTOR 550



# ↓ POWERSCREEN PULSE

## RECORD, DISPLAY AND ANALYSE DATA: HIGH EFFICIENCY THROUGH PRECISE INFORMATION

Available online anywhere and at any time: comprehensive information on the GPS location, start and stop times, fuel consumption, tonnages, cone settings, wear ratings, operating hours, maintenance status, and much more.



**AVAILABLE ANYWHERE AND AT ANY TIME**



**DASHBOARD DISPLAY**



**FLEET OVERVIEW**



**WEEKLY REPORT DIRECT TO YOUR INBOX**



**GPS: MACHINE TRACKING**



**REPORTING UTILISATION, PERFORMANCE & PART SPECIFIC**



## TRAKPACTOR 550



# ↓ DIMENSIONS

Figure 1: Trakpactor 550 - Pre-screen, Standard Product Conveyor Working Position

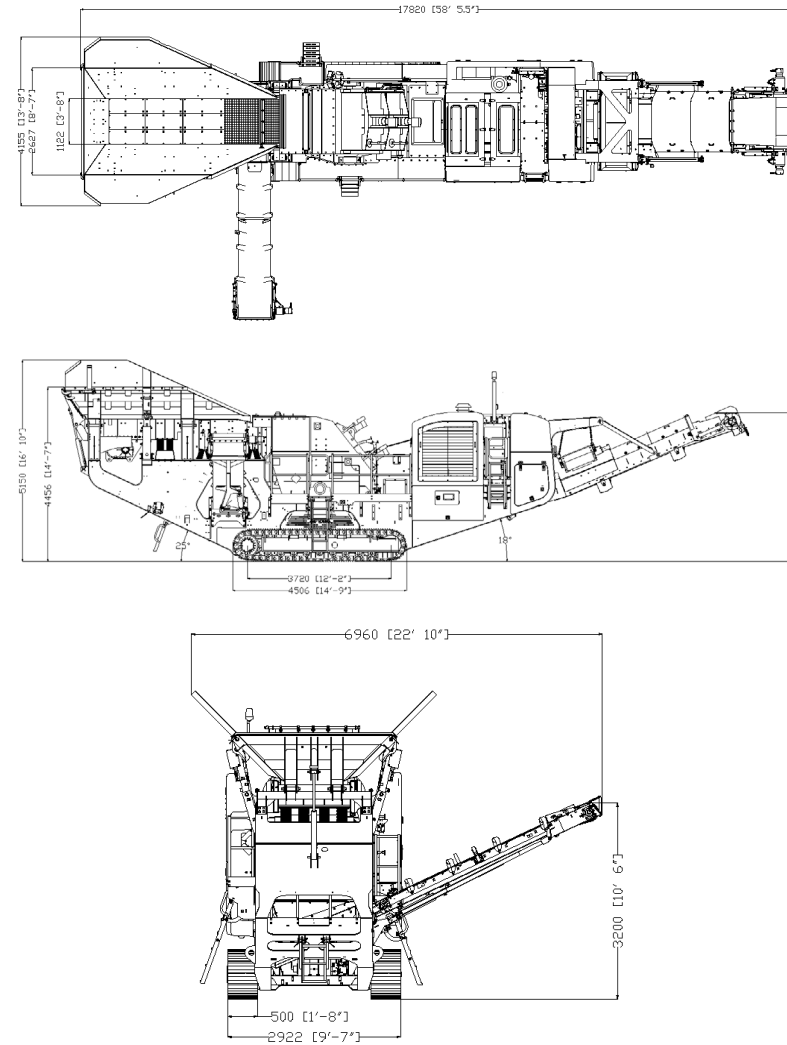

MORE DIMENSIONS OVERLEAF



## TRAKPACTOR 550



# DIMENSIONS

Figure 2: Trakpactor 550 - Pre-screen, Standard Product Conveyor  
Transport Position

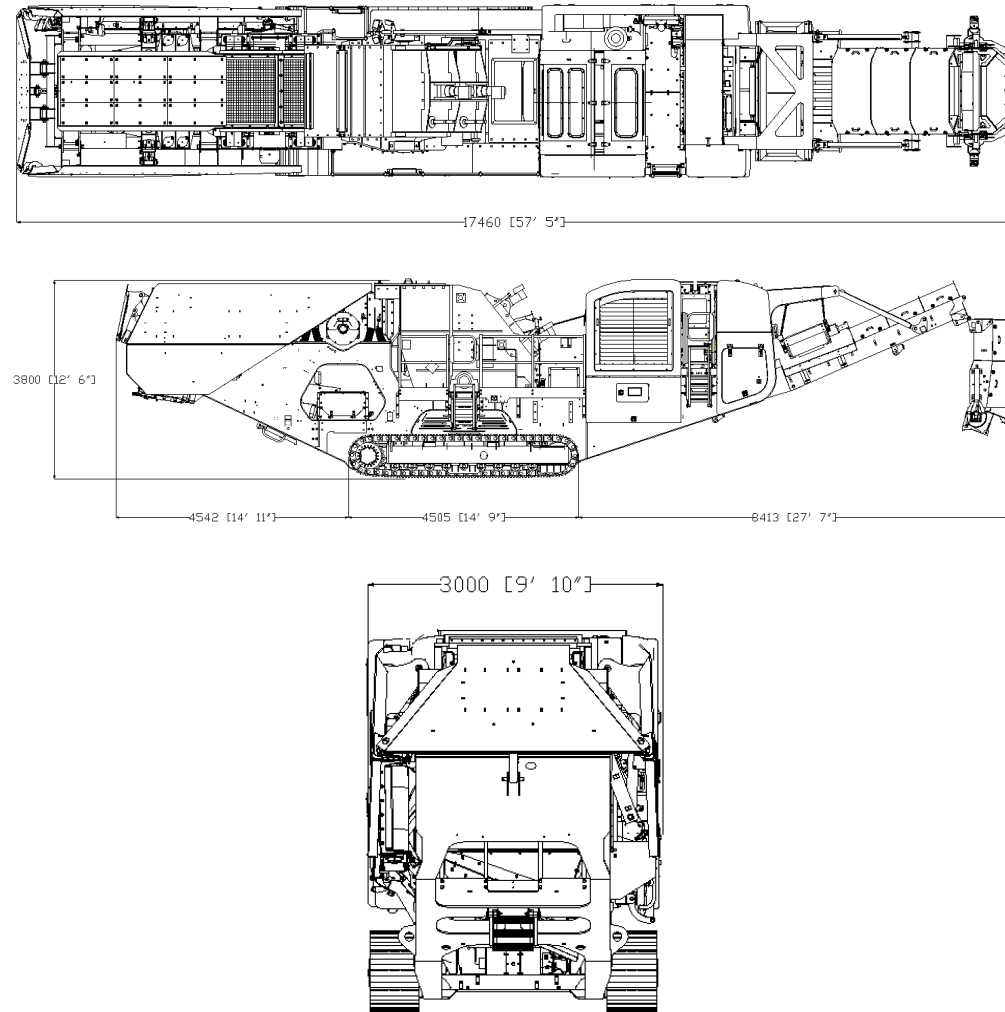

[MORE DIMENSIONS OVERLEAF](#)



## TRAKPACTOR 550



# DIMENSIONS

Figure 3: Trakpactor 550 - Pre-screen, Extended Product Conveyor Working Position

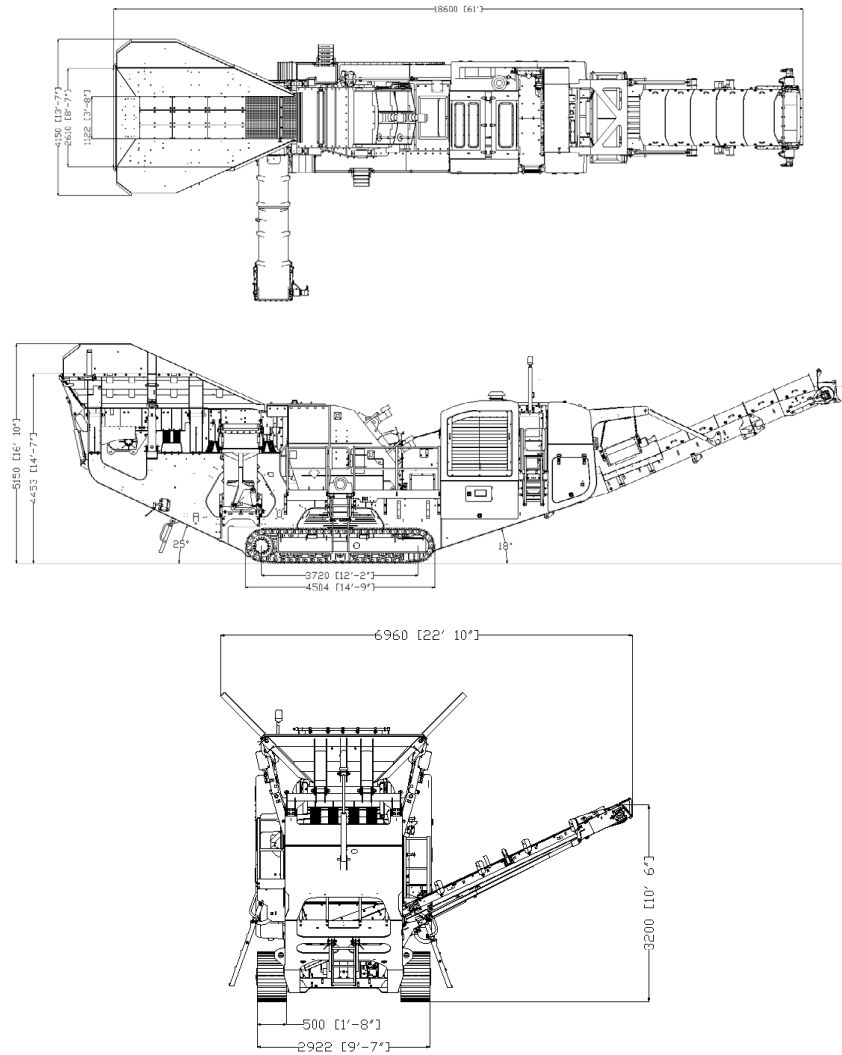

MORE DIMENSIONS OVERLEAF



## TRAKPACTOR 550



# DIMENSIONS

Figure 4: Trakpactor 550 - VGF, Standard Product Conveyor  
Working Position

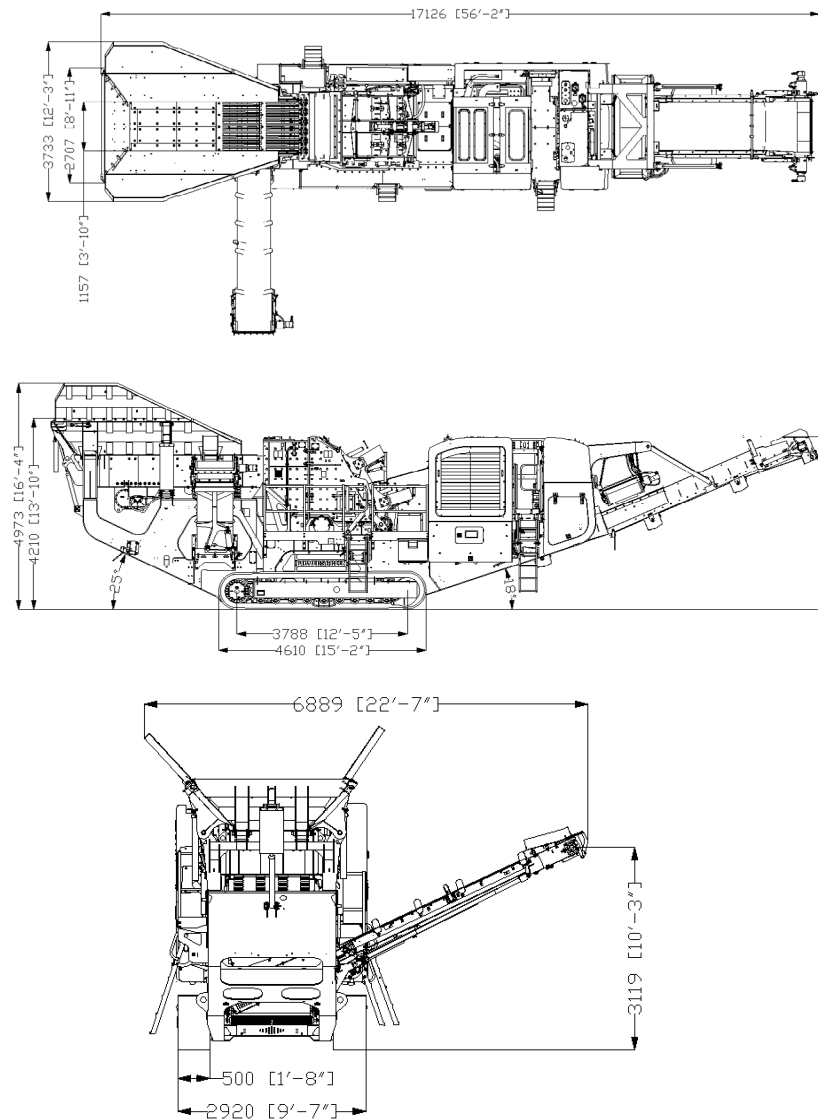

MORE DIMENSIONS OVERLEAF



## TRAKTRACTOR 550



# DIMENSIONS

Figure 5: Traktractor 550 - VGF, Standard Product Conveyor  
Transport Position

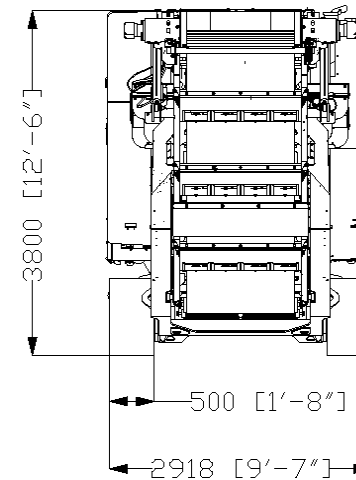
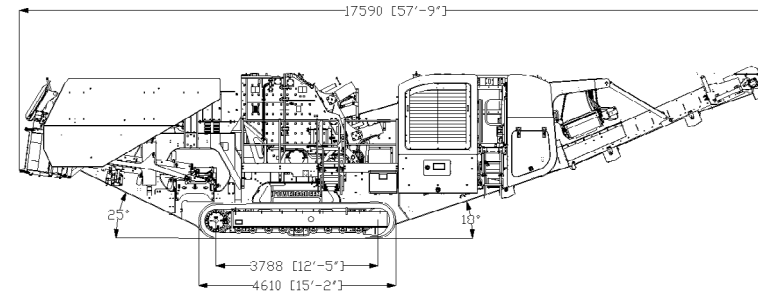
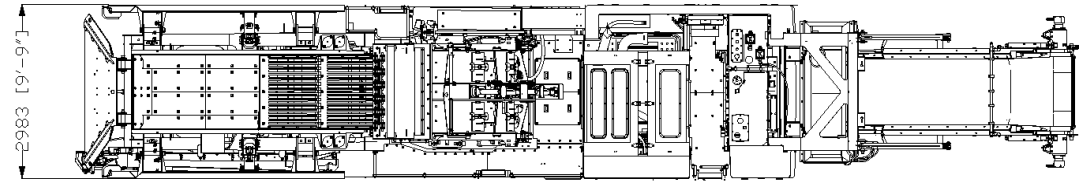



### **Powerscreen equipment complies with CE requirements.**

Please consult Powerscreen if you have any other specific requirements in respect of guarding, noise or vibration levels, dust emissions, or any other factors relevant to health and safety measures or environmental protection needs. On receipt of specific requests, we will endeavour to ascertain the need for additional equipment and, if appropriate, quote extra to contract prices.

All reasonable steps have been taken to ensure the accuracy of this publication, however due to a policy of continual product development we reserve the right to change specifications without notice.

It is the importers' responsibility to check that all equipment supplied complies with local legislation regulatory requirements.

Plant performance figures given in this brochure are for illustration purposes only and will vary depending upon various factors, including feed material gradings and characteristics. Information relating to capacity or performance contained within this publication is not intended to be, nor will be, legally binding.

## **GET IN TOUCH**

### **Dungannon**

200 Coalisland Road, Dungannon,  
Co Tyrone, BT71 4DR, Northern Ireland  
Tel: +44 (0) 28 87 718 500  
Fax: +44 (0) 28 87 747 231

### **Louisville**

11001 Electron Drive,  
Louisville, Kentucky, 40299 USA  
Tel: +1 502 736 5200  
Fax: +1 502 736 5202

