

# POWERSCREEN® TRAKPACTOR 550SR

HORIZONTAL IMPACTOR



TECHNICAL SPECIFICATION - REV 1.1 01/08/2019





## TRAKPACTOR 550SR



# OVERVIEW

### SPECIFICATION

<b>Total Weight PS:</b>	Tier 4F: 72,000kg (158,733lbs) Underpan, hopper extensions, bypass conveyor, single pole magnet
<b>Total Weight VGF:</b>	Tier 3: 66,800kg (147,269lbs) 4 full blow bars, bypass conveyor, single pole magnet
<b>Transport</b>	<b>Length</b> 21.45m (70' 4") PS <b>Height</b> 3.8m (12' 6") <b>Width</b> 3.46m (11' 4")
<b>Working</b>	<b>Length</b> 21.31m (69' 11") PS <b>Height</b> 5.83m (19' 2") <b>Width</b> 6.99m (22' 11") with bypass conveyor deployed
<b>Crusher Type:</b>	Twin apron 4 bar impact crusher, feed opening 1370mm x 911mm (54" x 36")
<b>Power Unit</b>	Tier 3 Caterpillar C13 328kW (440hp), Tier 4 Scania DC13 368kW (494hp) or Constant Speed Scania DC13 371kW (498hp)
<b>Plant Colour</b>	RAL 5021, RAL 7024, RAL 9005

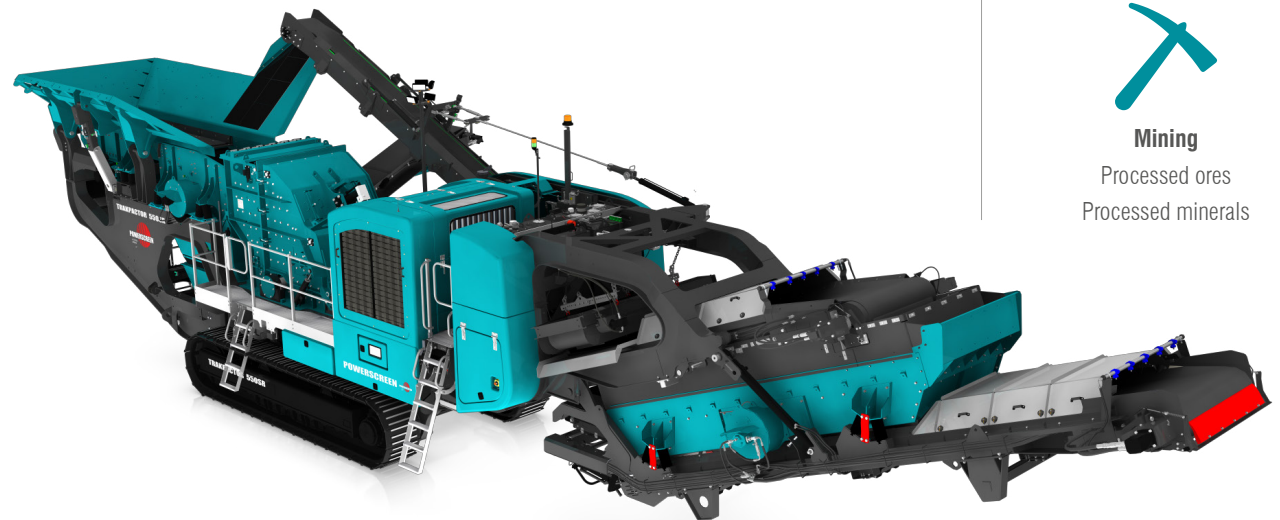

### APPLICATIONS



**Aggregate**  
Blasted rock  
River rock



**Recycling**  
C&D waste  
Foundry waste



**Mining**  
Processed ores  
Processed minerals



## TRAKPACTOR 550SR



# FEATURES & BENEFITS

The Powerscreen® Trakpactor 550SR horizontal shaft impactor is designed for processing soft to medium-hard primary & secondary materials such as natural rock & construction derived materials like asphalt, recycling & demolition waste. Material is fed into the large feed hopper, common on both vibrating grizzly feeder & live pre-screen versions in which both feature a selectable crusher bypass facility & optional fines discharge conveyor. Load sensing ensures the wide crusher inlet opening receives a continuous feed of pre-screened material, avoiding unnecessary crusher wear.

The Powerscreen® Trakpactor 550SR's robust impact chamber features a twin apron, 4 bar rotor design, with hydraulic release aprons, hydraulic setting adjustment, hydraulic crusher overload & is driven directly off the engine via clutch for optimum fuel economy. Next, crushed material passes; either over the independent under pan feeder & modular product conveyor, or directly onto the full length conveyor. Both conveyors feature a raise/lower facility to aid clearance of rebar in the event of a blockage. The plant has been designed with ease of maintenance in mind. Hydraulic banks, battery access and control valves are at eye level to make setup and operation much easier. The SR section is fully detachable using quick release hydraulics and electrics. To enable this, the recirculation conveyor slews into transport position along the side of the machine. The recirculating conveyor can also slew from recirculating to stockpiling position.

- Output potential of up to 500 tph / 550 US tph - depending on material type & crusher settings
- Suitable for a variety of feed materials, ideal for recycling, demolition & quarry applications
- Double deck grizzly feeder with under screen
- Load management system to control feeder speed
- Proven impact crusher with hydraulic overload protection, 4 bar rotor & twin apron design
- Hydraulic inlet lid allows 'near-size' pieces to enter chamber without blocking inlet (Terex chamber only)
- Hydraulic autoset CSS adjustment (optional on Terex chamber only)
- Heavy duty under crusher impact bars as standard
- Fully independent under crusher vibrating pan feeder (optional)
- Bypass conveyor selection on either side of plant (optional)
- Chamber drive via clutch & highly fuel efficient direct drive system
- Crusher speed variation through user friendly PLC control system
- Live pre-screen (optional)
- Hydraulic raise/lower magnet
- SR section can slew from recirculating to stockpiling position
- SR section detaches using quick release hydraulics & electrics



## TRAKPACTOR 550SR



# ↓ CRUSHER

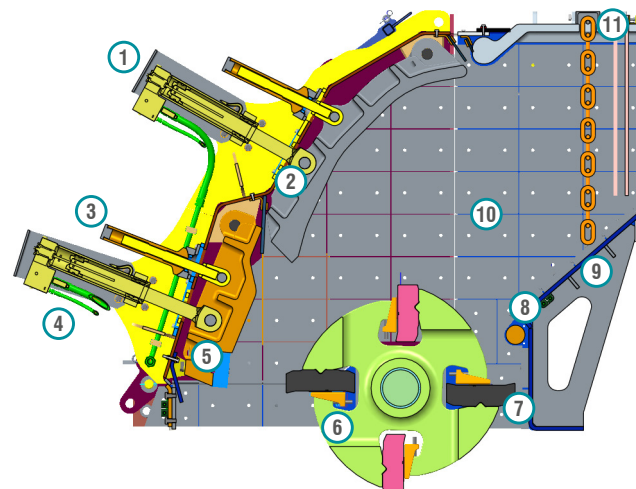

### PRINCIPAL COMPONENTS

- |   |                                 |
|---|---------------------------------|
| 1: Control Cylinder                                     | 7: Full Blow Bar                |
| 2: Top Impact Apron                                     | 8: Inlet Wear Beam              |
| 3: Apron Adjustment Spindle                             | 9: Inlet Plate                  |
| 4: Control Cylinder (Auto Adjust Apron Setting Control) | 10: Wear Liners                 |
| 5: Bottom Impact Apron                                  | 11: Crusher Hydraulic Inlet lid |
| 6: Rotor  |                                 |

### PRINCIPLES OF OPERATION

Material enters via the crusher opening & slides down the inlet chute where it is struck by the blow bar which is held within the rotor. This initial impact breaks the material which is then accelerated onto the top apron where more reduction takes place on impact. This material then falls back into the blow bars & the cycle repeated until the material is small enough to pass between the apron & the blow bar. Once through this gap, further reduction occurs on the bottom apron until the material

can again pass through the gap & discharge from the underside of the crusher.

Any un-crushable material entering the chamber will relieve the overload cylinders & allow the material to pass. The cylinders will then return to the pre-set crushing position. The pre-set gap is adjusted by turning the adjustment spindle whilst the weight of the apron is held on the cylinder (hydraulic assist).



## TRAKPACTOR 550SR



# CRUSHER SPECIFICATION

<b>Feed opening:</b>	1370mm x 911mm (54" x 36")
<b>Max lump size*:</b>	500mm <sup>3</sup> (20in <sup>3</sup> ) / 860mm (34") diagonally / 1000 x 1000 x 200mm (39 x 39 x 8") slab (blasted rock (limestone type): 600 x 600 x 600mm) *depending on material & blow bar specification
<b>Rotor width:</b>	1330mm (52")
<b>Rotor diameter:</b>	1210mm (47")
<b>Number of aprons:</b>	2
<b>Max clearance:</b>	Top apron: 265mm (10.5") Bottom apron: 305mm (12")
<b>Max OSS setting:</b>	200mm (7.9") upper apron, 200mm (7.9") lower apron
<b>Min CSS setting:</b>	35mm (1.4") upper apron, 20mm (0.8") lower apron
<b>Blow bars:</b>	Total of 4 blow bars
<b>Blow bar removal:</b>	Vertically
<b>Blow bar configuration:</b>	2 full & 2 half (optional 4 full)
<b>Setting adjustment:</b>	Auto adjust / hydraulic assist
<b>Overload protection:</b>	Hydraulic
<b>Rotor speeds:</b>	537 - 694rpm (34 - 44m/s) (111 - 144ft/s)
<b>Applications:</b>	Demolition / recycling / quarry
<b>Crusher weight:</b>	14540kg (32,055lbs)
<b>Full blow bar weight:</b>	410kg (904lbs)
<b>Side liners:</b>	20mm (thick, abrasive resistant steel)

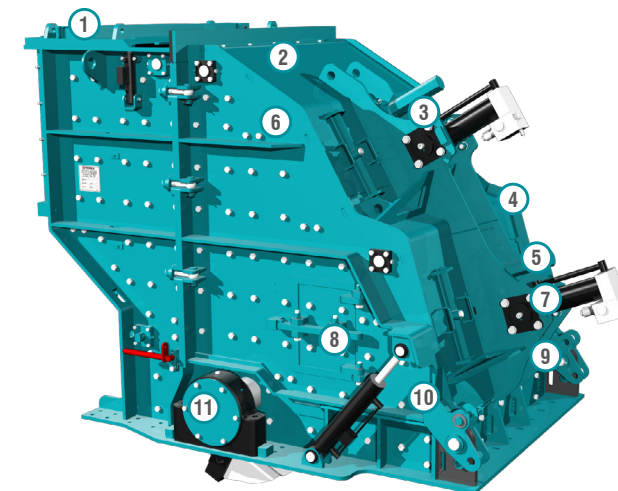

### PRINCIPAL COMPONENTS

- 1: Hydraulic inlet lid
- 2: Main welded body
- 3: Impactor hinged section
- 4: Inspector covers
- 5: Hydraulic overload & adjustment cylinders
- 6: Toggle bolts
- 7: Inspection covers
- 8: Side door
- 9: Trunions
- 10: Hinged section opening cylinder
- 11: Bearings



## TRAKPACTOR 550SR



# CRUSHER FEATURES

- Crusher body:** Fabricated from steel plate & fully lined with replaceable abrasion resistant liner plates. Hinged side door allows access to apron tips & rotor for gap measurements & inspection. Complete hinged section opens hydraulically to allow blow bar removal & replacement, apron & liner replacement or major maintenance
- Rotor:** Cast steel & fitted with 4 reversible & replaceable blow bars
- Bearings:** Double row self aligning spherical roller bearing fitted each end of rotor
- Aprons:** Cast steel aprons with replaceable abrasion resistant wear plate on tip of bottom apron
- Drive:** Direct through wedge belts with tensioning system on the power unit
- Lubrication:** Rotor bearings are greased & fitted with inner & outer labyrinth seals
- Blow bars:** Standard blow bar is martensitic steel, options are available in martensitic ceramic, medium chrome, medium chrome ceramic, high chrome, high chrome ceramic & toughened chrome

## APPLICATIONS

This plant is designed for both demolition & quarrying applications. When fitted with martensitic or ceramic blow bars the crusher will tolerate small quantities of steel reinforcing bar in the feed. However, the machine is not designed to accept large pieces (maximum 20mm diameter, 500mm long) of steel or other uncrushable objects, & the feed material should be assessed / inspected for suitability prior to crushing. It is vitally important that large pieces of steel or similar un-crushable objects are not allowed to enter the crushing chamber as severe damage & injury may occur.

When high chrome bars are fitted, **all** steel should be removed from the feed material & the machine should only be used on quarry applications, or clean materials such as asphalt.

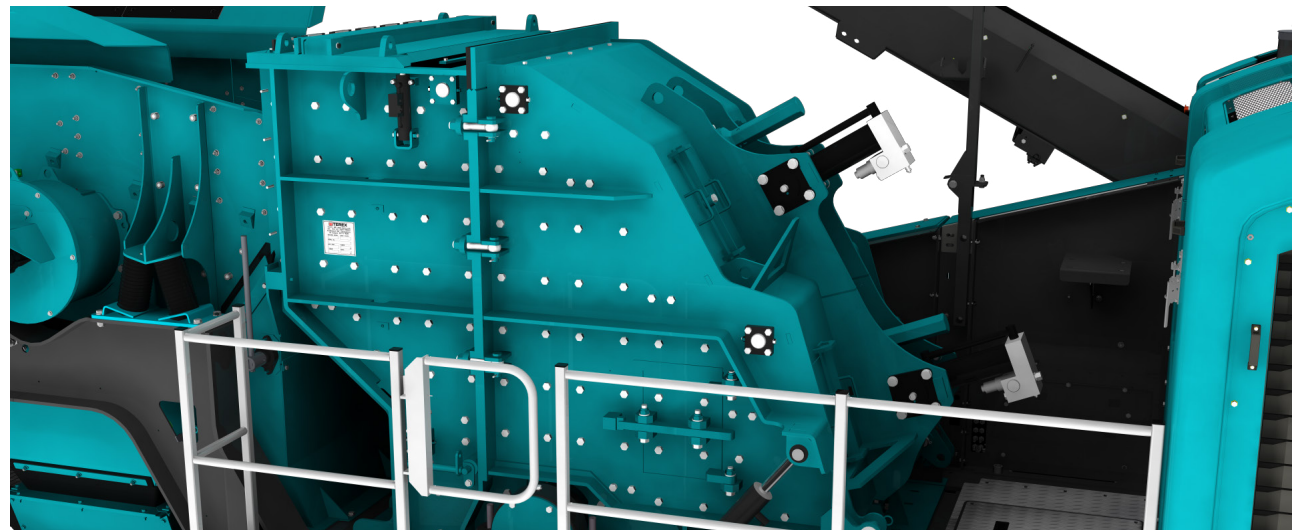



## TRAKFACTOR 550SR



# ↓ HOPPER

Hydraulic folding hopper with over centre struts & wedge-lock system

**Loading length:** 4.28m (14')

**Hopper width:** 2.71m (8' 11")

**Hopper capacity:** 7m<sup>3</sup> (9.2 cu. yd.)

**Hopper body:** 12mm thick abrasion resistant steel plate

Hydraulic locking as standard.

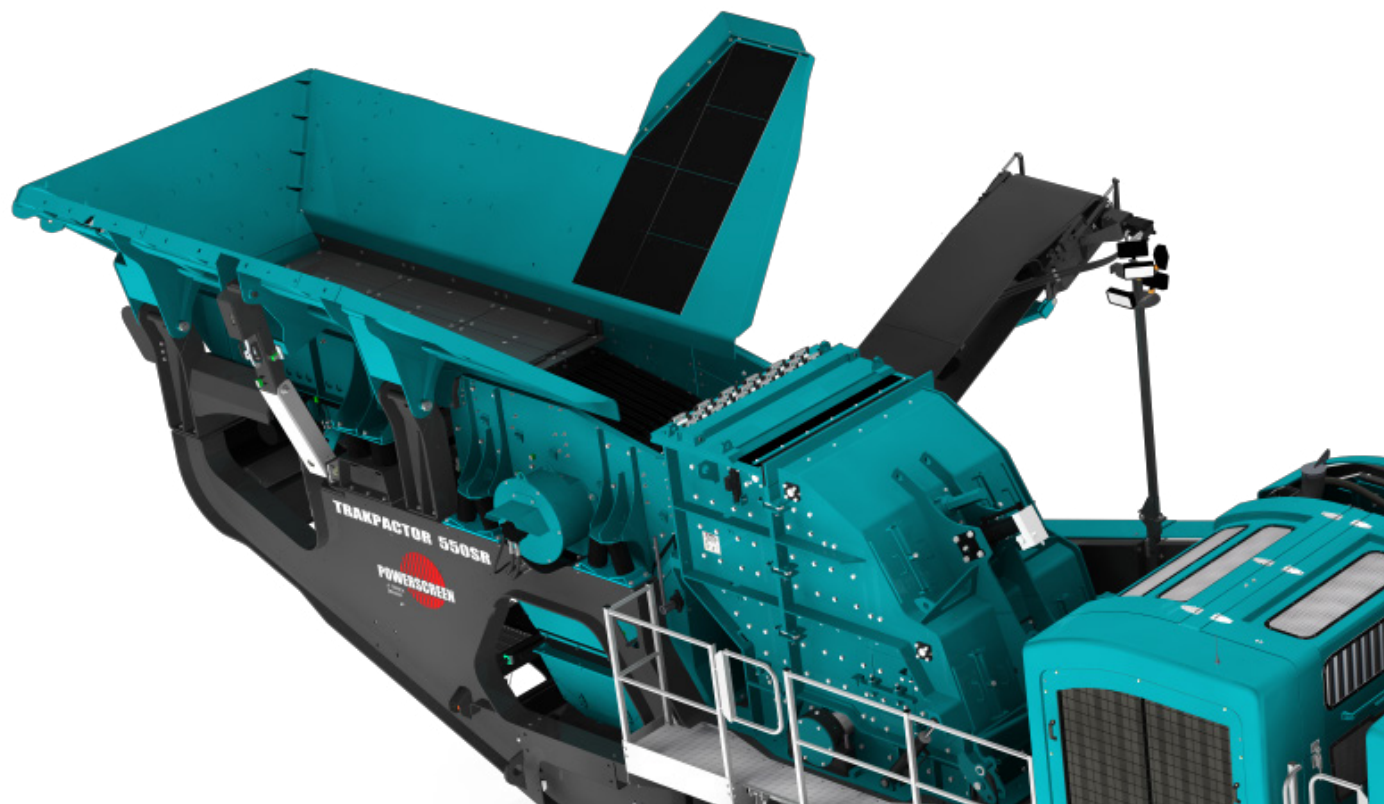



## TRAKPACTOR 550SR



# VIBRATING GRIZZLY FEEDER

<b>Type:</b>	Spring mounted vibrating	<b>Mesh:</b>	Blanking mat standard, underscreen mesh available in 10mm (0.4"), 20mm (0.8"), 30mm (1.2"), 40mm (1.6") & 50mm (2")
<b>Vibrating unit:</b>	Twin heavy duty cast eccentric shafts running in spherical roller bearings. Gears coupled at drive end	<b>Punch plate:</b>	Available in 30mm (1.2"), 38mm (1.5"), 50mm (2"), 60mm (2.4"), 63mm (2.5") & 75mm (3")
<b>Length:</b>	4.06m (13' 4")	<b>Chute:</b>	Plant is fitted with a bypass chute, with an internal two way flap door to control direction of fines, either forward onto the product belt or down onto the optional bypass conveyor (if blanking mat is fitted)
<b>Width:</b>	1.27m (4' 2")		
<b>Pan:</b>	12mm (0.5") thick abrasion resistant steel base plate liners		
<b>Drive:</b>	Flange mounted hydraulic motor		
<b>Grizzly:</b>	2m (6' 7") long double section of welded tapered finger bars at 34mm (1.33") as standard or 38mm (1.5"), 50mm (2"), 60mm (2.4"), 63mm (2.5") & 75mm (3") optional nominal spacing fabricated in 20mm thick abrasion resistant steel		

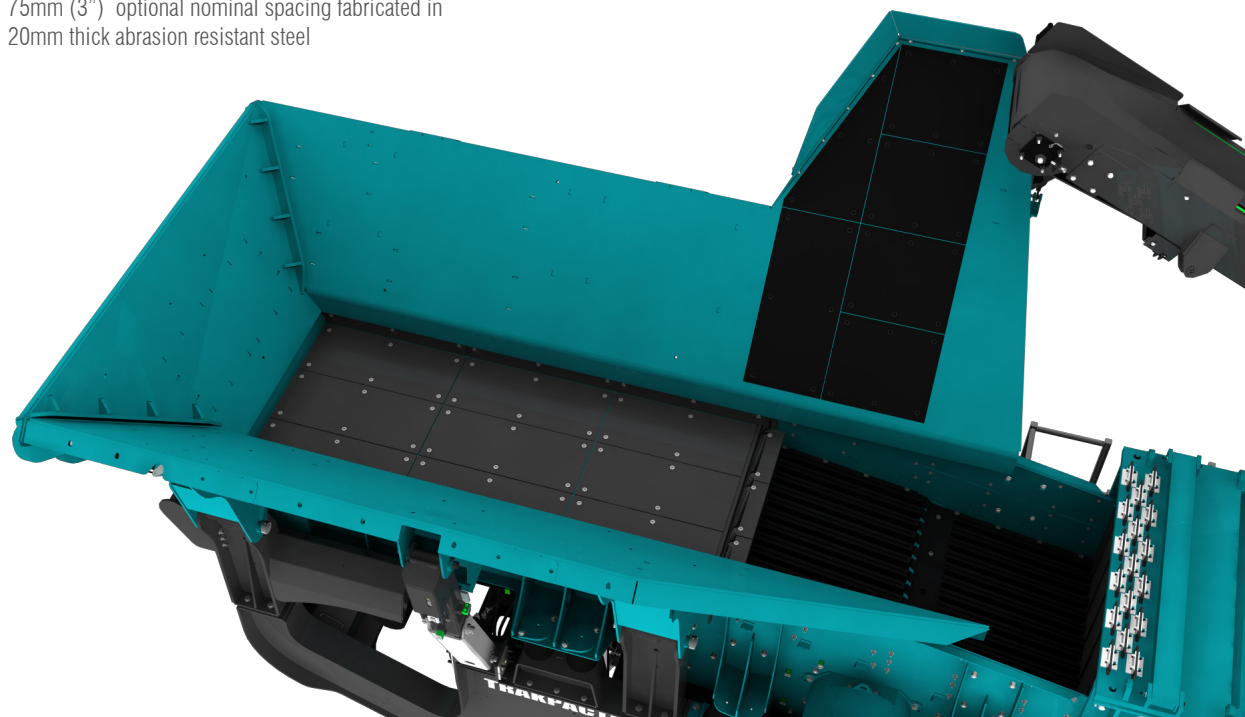



## TRAKPACTOR 550SR



# PRODUCT CONVEYOR

<b>Conveyor type:</b>	Fully removable modular unit. Shallow troughed with winged rollers & fully tunnelled with minimal snag areas
<b>Belt type:</b>	Ripstop EP500/3 8+2 with steel wire breaker ply
<b>Belt width:</b>	1200mm (3' 11")
<b>Discharge height:</b>	3.8m (12' 6") when fully raised
<b>Stockpile volume:</b>	101m <sup>3</sup> (132 cu. yd.)
<b>Feedboot:</b>	Fabricated steel with abrasion resistant steel liners
<b>Impact area:</b>	Heavy duty under crusher impact bars
<b>Skirting:</b>	Fully skirted in wear resistant rubber up to magnet discharge area
<b>Drive:</b>	Dual hydraulic motor direct to head drum
<b>Lubrication:</b>	Centralised grease points for lubrication of shaft bearings
<b>Belt covers:</b>	Optional aluminium removable dust covers
<b>Belt adjustment:</b>	Belt tensioning is by use of screw adjustment at the head drum
<b>Speed wheel:</b>	Designed to stop plant feed if the discharge conveyor slows or stops

## DUST SUPPRESSION SYSTEM

Spray bars with atomiser nozzles mounted over product conveyor & final conveyor discharge, piped to an inlet manifold for customer water supply or optional pump.

<b>Type:</b>	Clean water multi atomising nozzles
<b>Inlet:</b>	Single point on chassis
<b>Inlet pressure:</b>	3 bar (44psi)
<b>Water supply:</b>	24 L/min (6.3G/min) minimum
<b>Frost protection:</b>	Via system main valves
<b>Pump:</b>	Optional

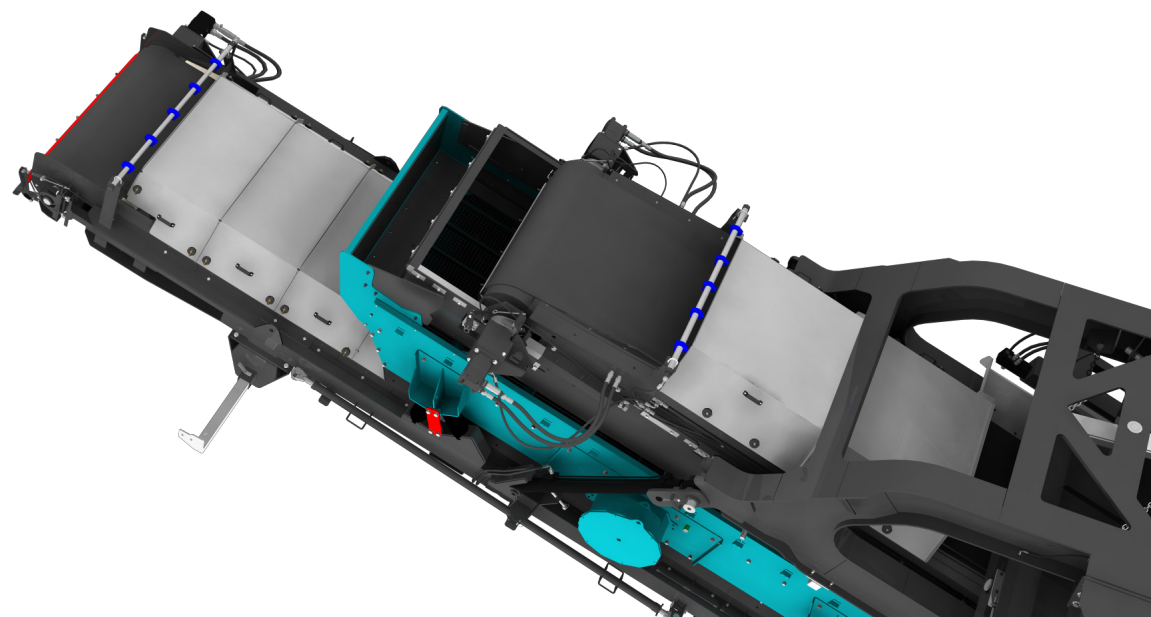



## TRAKTRACTOR 550SR



# ↓ POWER UNIT & HYDRAULICS

<b>Tier 3 Equivalent:</b>	Caterpillar C-13 ACERT, 6 cylinder, 328 kW (440hp)
<b>Operating conditions:</b>	Ambient temp. +30°C to -5°C (86°F to 23°F) at altitudes up to 2000m (6562ft) above sea level - For applications outside this range please consult with Powerscreen as the plant performance / reliability may be affected.
<b>Operating rpm range:</b>	1700 - 2100rpm
<b>Emission control technique:</b>	Not applicable
<b>Plant drive:</b>	High quality tandem pumps driven via engine PTO's
<b>Clutch type:</b>	Desch Revox 14" wet clutch
<b>Tier 4F / Stage IV:</b>	Scania DC13 385A - 368kW (494hp)
<b>Operating conditions:</b>	Ambient temp. +30°C to -5°C (86°F to 23°F) at altitudes up to 2000m (6562ft) above sea level - For applications outside this range please consult with Powerscreen as the plant performance / reliability may be affected
<b>Operating rpm range:</b>	1500 - 1900rpm
<b>Emission control technique:</b>	Selective Catalytic Reduction (SCR)
<b>Reductant tank size:</b>	60 L (16 US Gal)
<b>Plant drive:</b>	High quality pumps driven via clutch PTO's
<b>Clutch type:</b>	Desch Revox 14" wet clutch
<b>Costant speed stage IIIA (EU Only):</b>	Scania DC13 371kW (498hp)
<b>Operating conditions:</b>	Ambient temp. +30°C to -5°C (86°F to 23°F) at altitudes up to 2000m (6562ft) above sea level - For applications outside this range please consult with Powerscreen as the plant performance / reliability may be affected

<b>Operating rpm range:</b>	1500 - 1900rpm
<b>Emission control technique:</b>	Not applicable
<b>Reductant tank size:</b>	60 L (16 US Gal)
<b>Plant drive:</b>	High quality pumps driven via clutch PTO's
<b>Clutch type:</b>	Desch Revox 14" wet clutch
<b>Fuel tank capacity:</b>	1100 L (290 US Gal)
<b>Hydraulic tank capacity:</b>	1060 L (280 US Gal)
<b>Crusher drive:</b>	Direct drive via wedge belts Clutch pulley diameter 425mm T4, 375mm T3 Crusher pulley diameter 800mm (39") Terex chamber, 800mm (39") Hazemag chamber Crushing performance can be tuned by changing engine speed via the PLC .
<b>Drive tensioning:</b>	VEE belt tensioner system





## TRAKPACTOR 550SR



# ↓ TRACKS

### TRACKS

<b>Type:</b>	Heavy duty tracks, bolted to chassis on pads & pins
<b>Sprocket centres:</b>	4.17m (13' 8")
<b>Track width:</b>	500mm (1' 8")
<b>Gradeability:</b>	30° maximum
<b>High speed:</b>	1.01kph (0.63 mph)
<b>Drive:</b>	Two integral hydraulic motors
<b>Tensioning:</b>	Hydraulic adjuster, grease tensioned

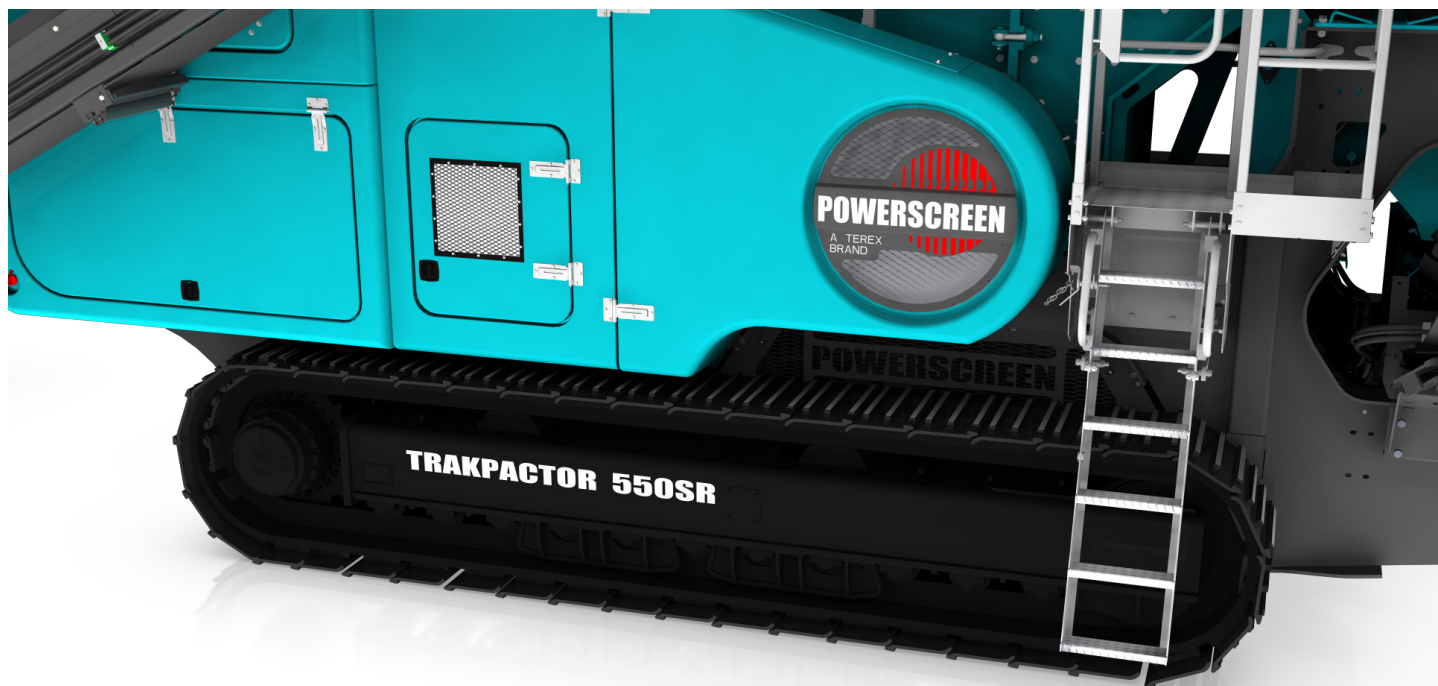



## TRAKPACTOR 550SR



# ↓ POST-SCREEN & CONVEYORS

### POST-SCREEN & FINES CONVEYOR

<b>Type:</b>	4.7m x 1.45m (15' 5" x 4' 9") single deck 2 bearing screen, side tension media
<b>Drive:</b>	Direct hydraulic motor
<b>Screen speed:</b>	1000rpm
<b>Angle:</b>	22°
<b>Belt width:</b>	1400mm (4' 7")
<b>Belt type:</b>	EP400/3 4+2 covers
<b>Discharge height:</b>	3.55m (11' 8")
<b>Stockpile volume:</b>	82m <sup>3</sup> (107 cu. yd.)
<b>Detach:</b>	Quick detach fitted as standard

### CROSS CONVEYOR

<b>Type:</b>	Flat belt EP400/3 4+2 covers
<b>Belt width:</b>	500mm (1' 8")
<b>Drive:</b>	Direct hydraulic motor
<b>Transport:</b>	Hydraulic retraction

### HYDRAULIC FOLDING RECIRCULATING CONVEYOR

<b>Type:</b>	Chevron belt EP315/3 3+1.5 covers
<b>Belt width:</b>	500mm (1' 8")
<b>Chevron:</b>	25mm (1")
<b>Drive:</b>	Direct hydraulic motor
<b>Stockpile:</b>	From under cross conveyor, or via feed chute

Conveyor can recirculate or slew around and stockpile - stockpile height - 5.43m (17'10") / Volume : 295m<sup>3</sup> (385 cu.yd).

All auxiliary functions on the SR section are controlled by radio remote as standard. The recirculating conveyor hydraulically folds alongside the SR section for transport. The complete SR section is then removed for transport via quick release hydraulics & electrics. The plant is now a one load transport which complies with required transport legislation.





## TRAKPACTOR 550SR



# PLANT CONTROLS & OTHER

### GUARDS

Wire mesh, sheet metal or GRP guards are provided for all drives, flywheels, pulleys & couplings.

The guards provided are designed & manufactured to CE & ANSI standards.

### PLATFORMS

Platforms are provided for maintenance on both sides of the feeder & impactor. These are fitted with double row handrails & access ladders. Platforms are also provided to gain access to the power unit and the rear of the crusher on the pre-screen model.

### CHASSIS

Heavy duty I-section of welded construction provides maximum strength & accessibility.

### PLANT CONTROLS

Full PLC control system

Full colour backlit screen

Complete pictorial user controls

Multi-function backlit menu buttons

Full system diagnostics

Sequential auto start up

Main controls

- Engine/crusher speed
- Feeder (start/stop/speed)
- Product conveyor + pan feeder (start/stop)
- Screen/fines/cross/recirculating (SR only)
- Product conveyor raise/lower
- Side conveyor
- Crusher control/screen setup

### UMBILICAL CONTROL

An umbilical control unit is supplied with the plant. This is used to control the tracking function & is also fitted with a stop button for the plant.





## TRAKPACTOR 550SR



# **HAZEMAG IMPACT CRUSHER**



### PRINCIPAL COMPONENT

- |                             |                                 |
|-----------------------------|---------------------------------|
| 1: Control Cylinder         | 7: Full Blow Bar                |
| 2: Top Impact Apron         | 8: Inlet Plate Control cylinder |
| 3: Apron Adjustment Spindle | 9: Inlet Wear Beam              |
| 4: Control Cylinder         | 10: Inlet Plate                 |
| 5: Bottom Impact Apron      | 11: Wear Liners                 |
| 6: Rotor                    | 12: Crusher Opening             |

### PRINCIPLES OF OPERATION

Material enters via the crusher opening & slides down the inlet chute where it is struck by the blow bar which is held within the rotor. This initial impact breaks the material which is then accelerated onto the top apron where more reduction takes place on impact. This material then falls back into the blow bars & the cycle repeated until the material is small enough to pass between the apron & the blow bar. Once through this gap, further reduction occurs on the bottom apron until the material

can again pass through the gap & discharge from the underside of the crusher.

Any un-crushable material entering the chamber will relieve the overload cylinders & allow the material to pass. The cylinders will then return to the pre-set crushing position. The pre-set gap is adjusted by turning the adjustment spindle whilst the weight of the apron is held on the cylinder (hydraulic assist)



## TRAKPACTOR 550SR



# HAZEMAG CRUSHER SPECIFICATION

<b>Feed opening:</b>	1360mm x 800mm (54" x 32")	<b>Number of blow bars:</b>	4
<b>Max lump size*:</b>	500mm <sup>3</sup> (20in <sup>3</sup> ) / 860mm (34") diagonally / 1000 x 1000 x 200mm (39 x 39 x 8") slab *depending on material blow bar specification	<b>Blow bar removal:</b>	Vertically
<b>Rotor width:</b>	1340mm (53")	<b>Blow bar configuration:</b>	2 full & 2 half (optional 4 full)
<b>Rotor diameter:</b>	1200mm (47")	<b>Setting adjustment:</b>	Hydraulic assist
<b>Number of aprons:</b>	2	<b>Overload protection:</b>	Hydraulic
<b>Maximum clearance:</b>	273mm (11") on both aprons	<b>Rotor speeds:</b>	540 - 630rpm (34 - 40m/s) (111 - 131ft/s)
<b>Maximum OSS setting:</b>	200mm (8") upper apron, 100mm (4") lower apron	<b>Applications:</b>	Demolition / recycling / quarry
<b>Minimum CSS setting:</b>	75mm (3") upper apron, 35mm (1.4") lower apron	<b>Crusher weight:</b>	14,855kg (32,750lbs)
		<b>Full blow bar weight:</b>	410kg (904lbs)
		<b>Side liners:</b>	20mm thick, abrasive resistant steel



## TRAKPACTOR 550SR



# HAZEMAG CRUSHER FEATURES

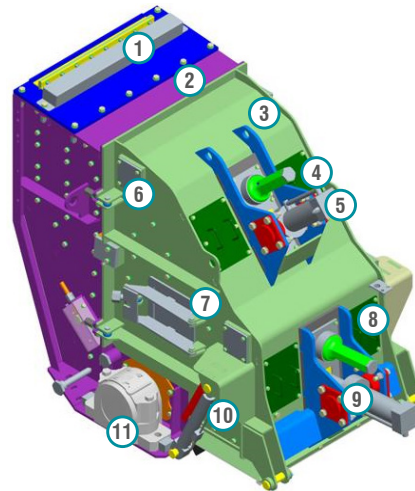

### PRINCIPAL COMPONENTS

- 1: Chain curtain cover
- 2: Main welded body
- 3: Impactor hinged section
- 4: Inspection covers
- 5: Hydraulic overload & adjustment cylinders
- 6: Toggle bolts
- 7: Side door
- 8: Inspection covers
- 9: Trunions
- 10: Hinged section opening cylinders
- 11: Bearings

### CRUSHER FEATURES

- Crusher body:** Fabricated from steel plate & fully lined with replaceable abrasion resistant liner plates. Hinged side door allows access to apron tips & rotor for gap measurements & inspection. Complete hinged section opens hydraulically to allow blow bar removal & replacement, apron & liner replacement or major maintenance
- Rotor:** Cast steel & fitted with 4 reversible & replaceable blow bars
- Bearings:** Double row self aligning spherical roller bearing fitted each end of rotor
- Aprons:** Cast steel aprons with replaceable abrasion resistant wear plate on tip of bottom apron
- Drive:** Direct through wedge belts with tensioning system on the power unit
- Lubrication:** Rotor bearings are greased & fitted with inner & outer labyrinth seals
- Blow bars:** Standard blow bar is martensitic steel, options available in high chrome & ceramic

### APPLICATIONS

This plant is designed for both demolition & quarrying applications. When fitted with martensitic or ceramic blow bars the crusher will tolerate small quantities of steel reinforcing bar in the feed. However, the machine is not designed to accept large pieces of steel or other uncrushable objects, & the feed material should be assessed / inspected for suitability prior to crushing. It is vitally important that large pieces of steel or similar un-crushable objects are not allowed to enter the crushing chamber as severe damage & injury may occur.

When high chrome bars are fitted, all steel should be removed from the feed material & the machine should only be used on quarry applications, or clean materials such as asphalt.



## TRAKPACTOR 550SR



# ↓ OPTIONS

### BYPASS CONVEYOR

<b>Conveyor type:</b>	Troughed EP400/3 4+2 covers hydraulically folding
<b>Belt width:</b>	800mm (2' 7")
<b>Discharge height:</b>	3.2m (10' 6")
<b>Stockpile volume:</b>	60m <sup>3</sup> (78 cu. yd.)
<b>Drive:</b>	Direct hydraulic motor
<b>Lubrication:</b>	Centralised grease points for lubrication of shaft bearings
<b>Position:</b>	RHS or LHS

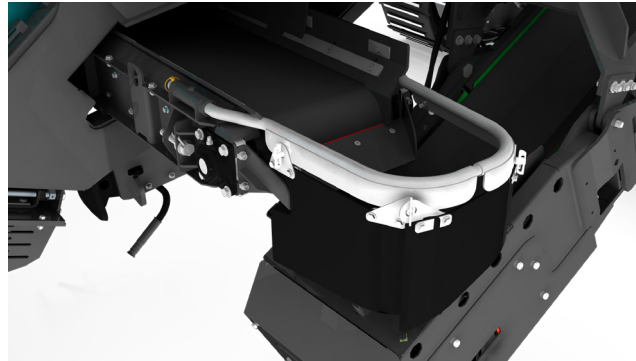

### PAN FEEDER & LIVE PRE-SCREEN

Vibrating pan feeder with 2 deck live pre-screen

<b>Pan type:</b>	Spring mounted vibrating pan
<b>Vibrating unit:</b>	Twin heavy duty cast eccentric shafts running in spherical roller bearings, gear coupled at drive end, flange mounted hydraulic motor
<b>Dimension length:</b>	2.9m (9' 6")
<b>Dimension width:</b>	1.2m (3' 11")
<b>Pan:</b>	15mm thick fully welded base plate with 12 mm thick abrasion resistant liners
<b>Pre-screen:</b>	Spring mounted vibrating unit with stepped finger bofor deck
<b>Vibrating unit:</b>	Single shaft, out of balance weights, flange mounted hydraulic motor
<b>Top deck dimensions:</b>	
<b>Length:</b>	2.1m (6' 11")
<b>Width:</b>	1.27 (4' 2")
<b>Bofor deck:</b>	2 stepped bolt in cartridges with 1m (39") long self cleaning fingers 50mm (2") nominal spacing as standard.
<b>Control:</b>	Variable speed control though control panel & (radio remote optional)
<b>Chute:</b>	Bypass chute with internal 2 way flap door fitted, to control direction of fines, either forward onto the product belt or onto the optional side conveyor (if blanking mat is fitted)
<b>Bottom deck dimensions:</b>	
<b>Length:</b>	1.6m (5' 3")
<b>Width:</b>	1.27 (4' 2")



## TRAKTRACTOR 550SR



## OPTIONS 2

### HOPPER EXTENSIONS

<b>Hopper width:</b>	3.96m (13')
<b>Hopper capacity:</b>	11m <sup>3</sup> (14.4 cu. yd.)
<b>Body:</b>	10mm thick abrasion resistant steel plate

### SINGLE POLE & TWIN POLE MAGNETS

<b>Magnet type:</b>	Suspended self cleaning over band with endless belt
<b>Magnet block:</b>	836 x 530mm (33" x 21")
<b>Drive:</b>	Direct drive hydraulic motor
<b>Control:</b>	Pre-set variable speed
<b>Discharge:</b>	Via stainless steel shedder plate Hydraulic raise / lower RHS discharge only

### BLOW BARS

Standard blow bars supplied with plant are 2 high & 2 half martensitic steel. 2 further options are available:

<b>High chrome:</b>	Suitable for medium to hard rock applications where no steel is present in the feed material. Good wear characteristics
<b>Ceramic:</b>	Suitable for applications with limited steel in feed. Improved wear characteristics over standard martensitic blow bars
<b>4 full blow bars:</b>	Available in all options

### ELECTRIC REFUELLING PUMP

A refuelling pump, allows fuel to be drawn from a remote source. Fuel transfer rate of 50 L/min (13 G/min).

### VIBRATING UNDERPAN FEEDER

<b>Type:</b>	Steel bodied vibrating feeder fitted with stainless steel liners, mounted under the crusher & designed to prevent any impact damage to the product conveyor
<b>Width:</b>	1.42m (4' 8")
<b>Length:</b>	2.59m (8' 6")
<b>Drive:</b>	Twin hydraulic driven out of balance vibrator units.
<b>Note:</b>	When a vibrating underpan feeder is selected, the short product conveyor belt which accompanies will have the following spec: EP500/4 8+2

### HOT/COLD CLIMATE OILS

Cold climate oils - (recommended for ambient temperatures between -20 to +30°C) - Hydraulic & lubrication oils only. Other component modifications may be required for low temperature operations. Please contact the Powerscreen sales & applications department with any queries.

Hot climate oils - (recommended for ambient temperatures between +15 to +50°C)

### CONTROL PANEL POSITIVE PRESSURISATION

An additional unit designed to reduce dust particles within the control panel.

A continuous flow of clean air is passed through the cabinet whilst the unit simultaneously filters out any particulate laden air.



## TRAKPACTOR 550SR



# ↓ OPTIONS 3

### OTHER OPTIONS

- Hazemag chamber
- 2 deck live pre-screen
- Grizzly decks 50mm, 63mm & 75mm
- Punch plates cartridges 38mm, 50mm, 63mm & 75mm
- Pre-screen meshes 25-75mm (1" - 3")
- High chrome blow bars
- Ceramic blow bars
- 4 full size blow bars in lieu of 2 full 2 half blow bars
- Heavy duty underpan feeder
- Auto adjust bottom apron (Terex chamber only)
- Reversible fan
- Folding product conveyor (4.2m stockpile height)
- Left and right hand bypass conveyor
- Single pole or twin pole over-band magnets (hydraulic raise/lower)
- Plant lighting
- Radio remote control
- Electric refuelling pump
- Mechanical belt weigher
- Hydraulic water pump for dust suppression
- Hot/cold climate oils
- Hopper extensions (11m<sup>3</sup>)
- Fuel Active delivery system
- Control panel positive pressurisation
- Dust suppression
- Slow speed pulley for reduced speed (Terex chamber only)



## TRAKTRACTOR 550SR



# ↓ POWERSCREEN PULSE

## RECORD, DISPLAY AND ANALYSE DATA: HIGH EFFICIENCY THROUGH PRECISE INFORMATION

Available online anywhere and at any time: comprehensive information on the GPS location, start and stop times, fuel consumption, tonnages, cone settings, wear ratings, operating hours, maintenance status, and much more.

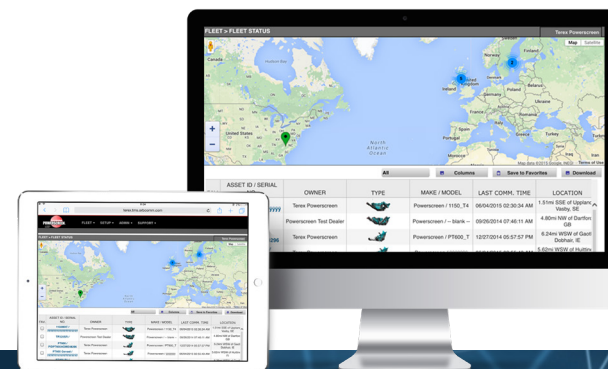



**AVAILABLE ANYWHERE AND AT ANY TIME**



**DASHBOARD DISPLAY**



**FLEET OVERVIEW**



**WEEKLY REPORT DIRECT TO YOUR INBOX**



**GPS: MACHINE TRACKING**



**REPORTING UTILISATION, PERFORMANCE & PART SPECIFIC**



## TRAKPACTOR 550SR



# DIMENSIONS

Figure 1: Trakpactor 550SR - Pre-screen, Standard Product Conveyor Working Position

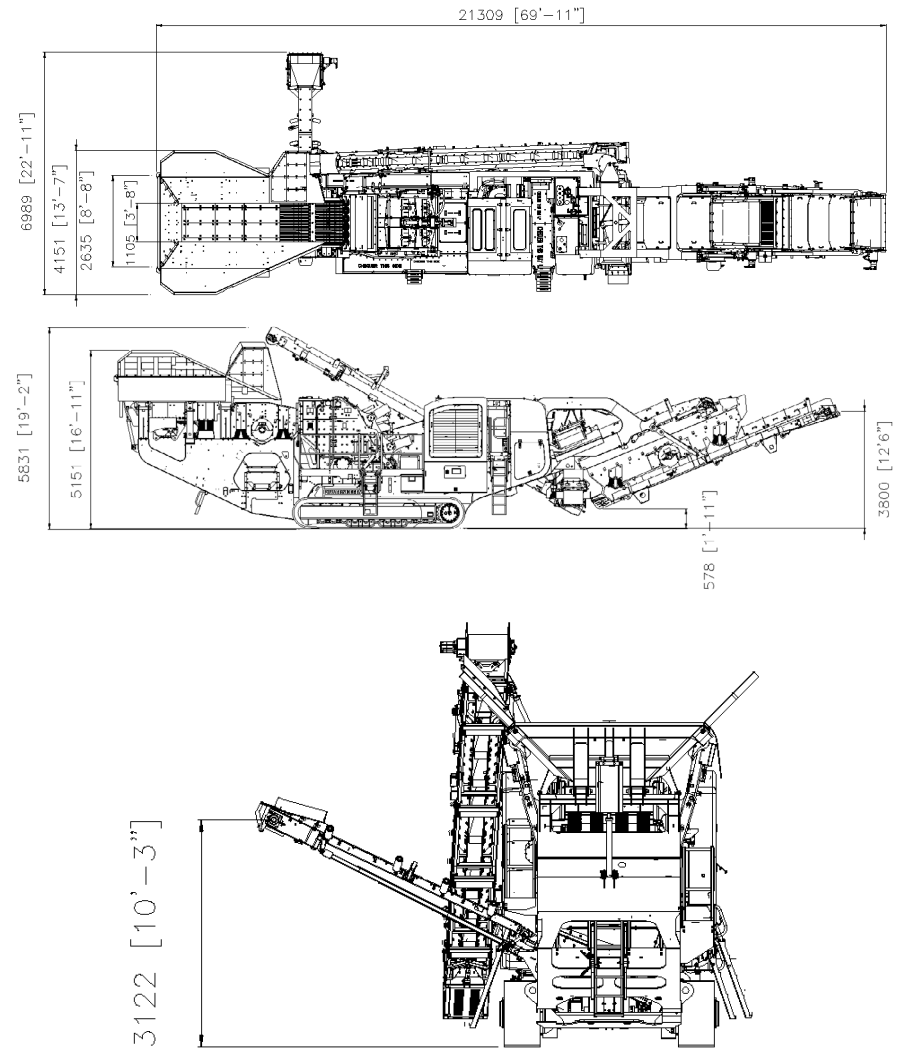

MORE DIMENSIONS OVERLEAF



## TRAKPACTOR 550SR



# DIMENSIONS

Figure 2: Trakpactor 550SR - Pre-screen, Standard Product Conveyor  
Transport Position

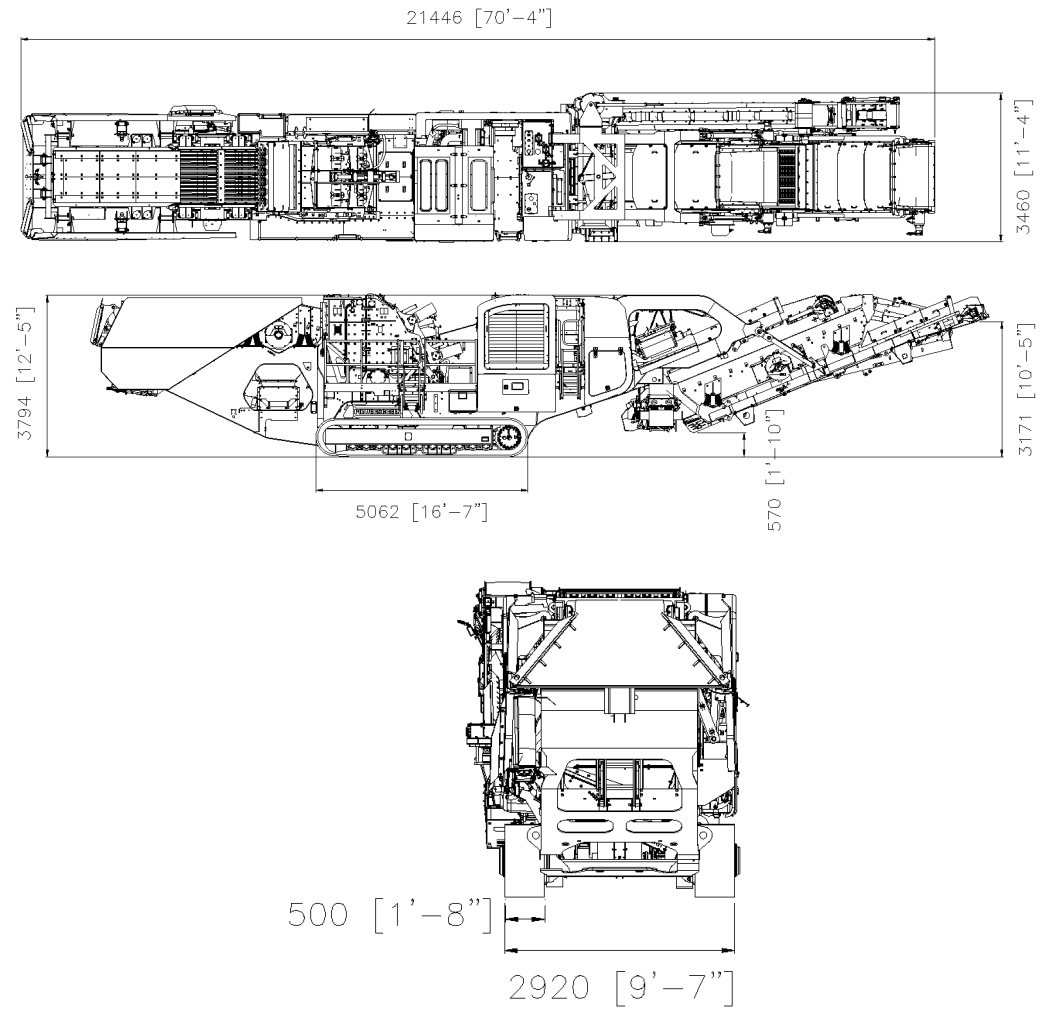

MORE DIMENSIONS OVERLEAF



## TRAKPACTOR 550SR



# DIMENSIONS

Figure 3: Traktractor 550SR - VGF, Standard Product Conveyor Working Position

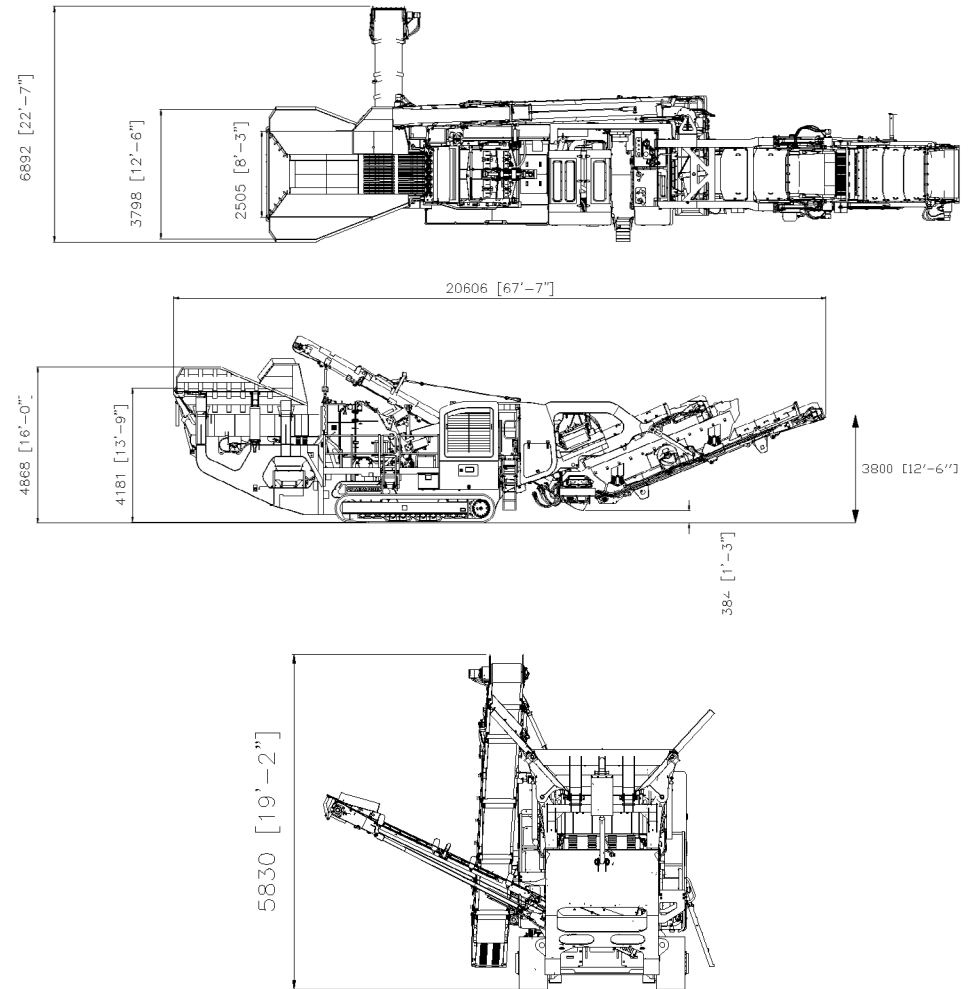

[MORE DIMENSIONS OVERLEAF](#)



## TRAKTRACTOR 550SR



# DIMENSIONS

Figure 4: Traktractor 550SR - VGF, Standard Product Conveyor  
Transport Position

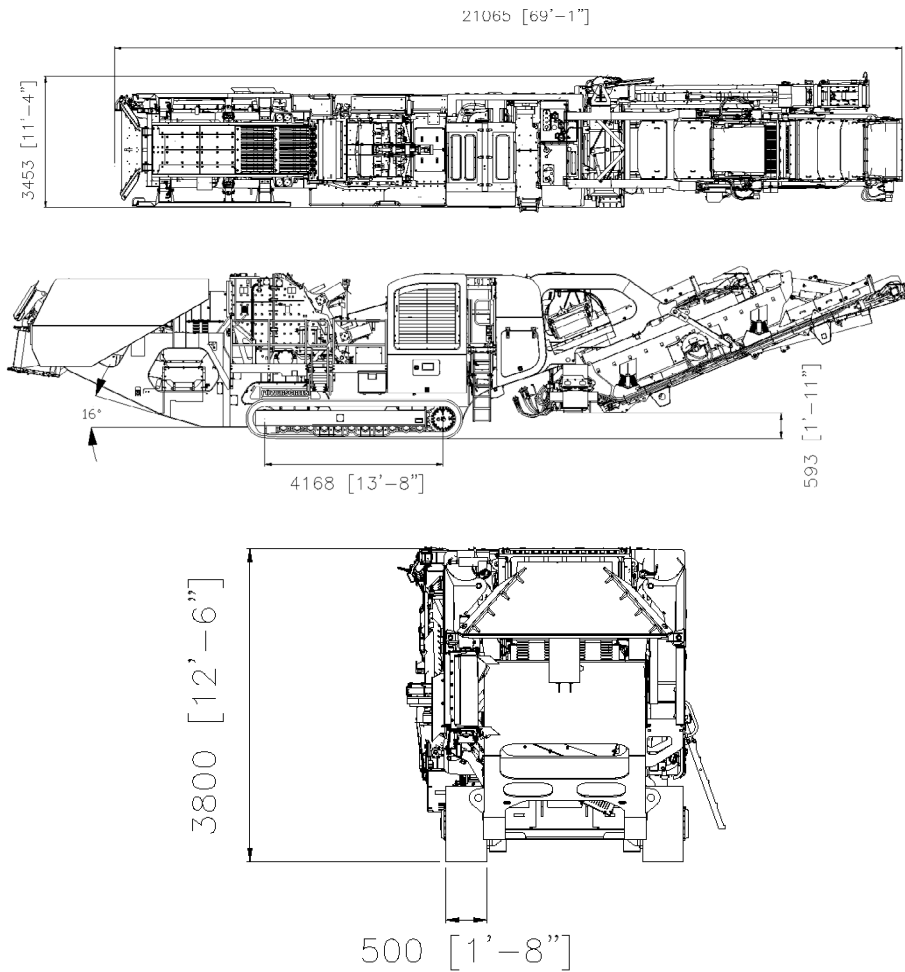

MORE DIMENSIONS OVERLEAF



## TRAKTRACTOR 550SR



# DIMENSIONS

Figure 5: Traktractor 550 - VGF, Standard Product Conveyor  
Transport Position

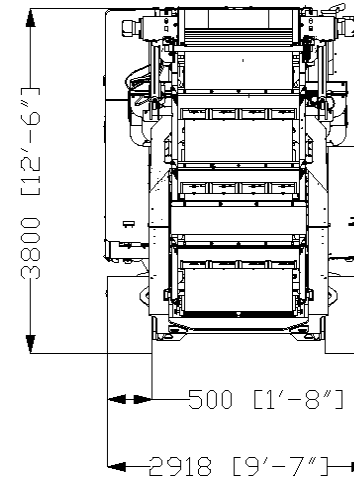
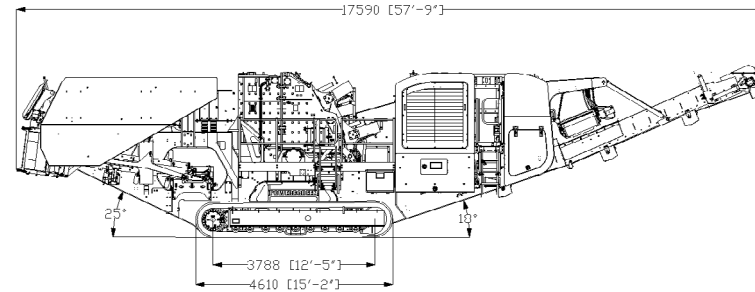
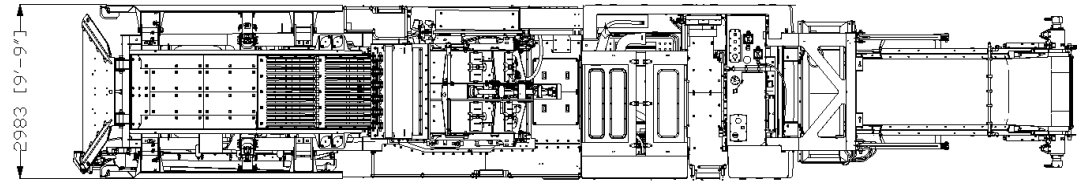



### **Powerscreen equipment complies with CE requirements.**

Please consult Powerscreen if you have any other specific requirements in respect of guarding, noise or vibration levels, dust emissions, or any other factors relevant to health and safety measures or environmental protection needs. On receipt of specific requests, we will endeavour to ascertain the need for additional equipment and, if appropriate, quote extra to contract prices.

All reasonable steps have been taken to ensure the accuracy of this publication, however due to a policy of continual product development we reserve the right to change specifications without notice.

It is the importers' responsibility to check that all equipment supplied complies with local legislation regulatory requirements.

Plant performance figures given in this brochure are for illustration purposes only and will vary depending upon various factors, including feed material gradings and characteristics. Information relating to capacity or performance contained within this publication is not intended to be, nor will be, legally binding.

## **GET IN TOUCH**

### **Dungannon**

200 Coalisland Road, Dungannon,  
Co Tyrone, BT71 4DR, Northern Ireland  
Tel: +44 (0) 28 87 718 500  
Fax: +44 (0) 28 87 747 231

### **Louisville**

11001 Electron Drive,  
Louisville, Kentucky, 40299 USA  
Tel: +1 502 736 5200  
Fax: +1 502 736 5202

