

POWERSCREEN®

CT-80

TRACKED CONVEYOR

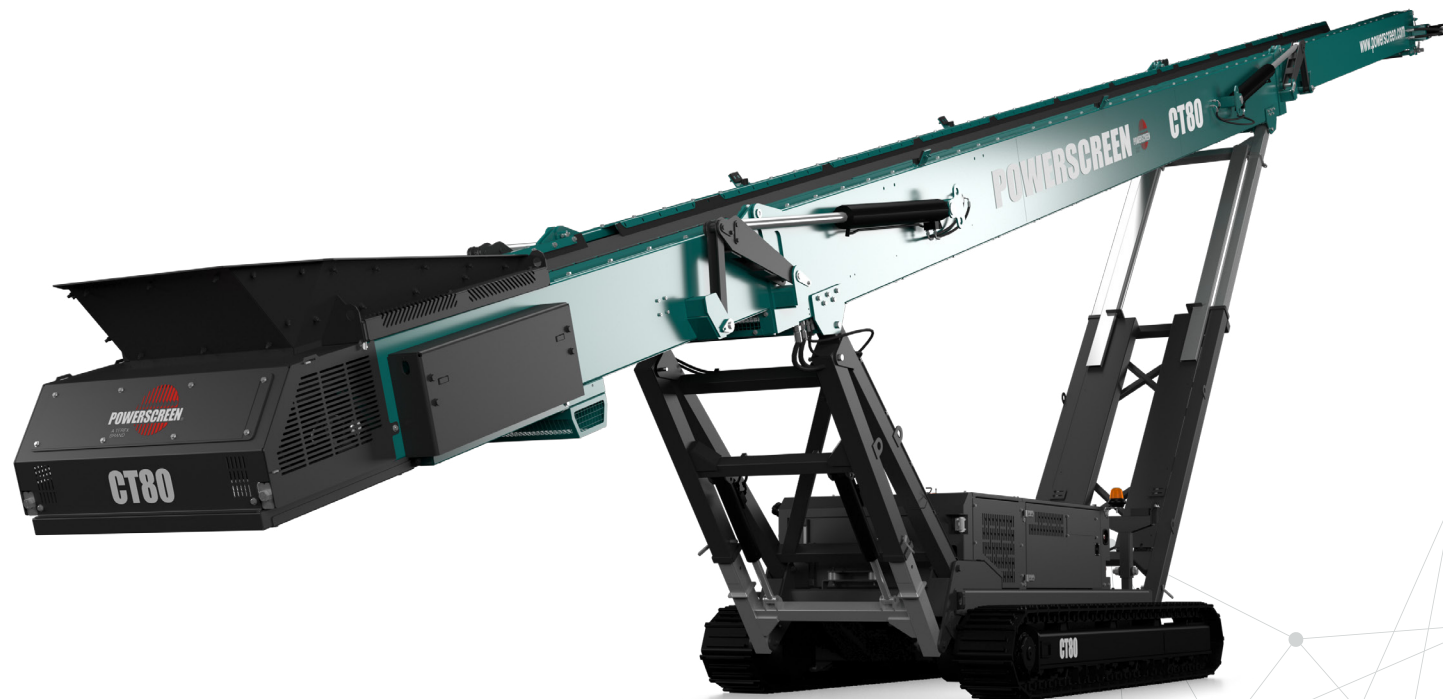

TECHNICAL SPECIFICATION - REV 2 01/02/2021





CT-80 TRACKED CONVEYOR



OVERVIEW

SPECIFICATION

Total Weight	16,750kg (36,927bs)
Transport	Length 11.88m (38' 11")
	Height 2.88m (9' 5")
	Width 2.25m (7' 4")
Working @ 24°	Length 21.4m (70' 3")
	Height 10.23m (33' 7")
	Width 2.25m (7' 4")
Power Unit	Tier 3: Deutz D2011 L04l 36.4kW (48hp) or, Tier 4F: Deutz TD 2.9 L04 45kW (60hp) or, Stage V: Deutz TD 2.9 L4 45kW (60hp)
Plant Colour	Blue RAL 5021, Grey RAL 7024

NOTE: Dimensions may differ slightly from sales drawings due to differences in angles / reference points.

FEATURES & BENEFITS

- High capacity up to 500tph (551 US tph).
- Maximum feed size up to 150mm (6").
- Eliminates the need for wheeled loaders to create stockpiles - reduces labour and maintenance costs.
- Eliminates the need for handling material multiple times - reduces labour and maintenance costs.
- Improved material quality due to reduced compaction, degradation, segregation and contamination.
- Can accept loads from multiple sources.
- Multiple hopper options available depending on required capacities and operators loading methods or application.
- Rapid set up time and manoeuvrability around site.
- Reduced fuel consumption due to reduced reliance on wheeled loaders.
- Reduced wear on wheeled loaders where a conveyor is utilised.
- Hydraulic folding head section.
- Tensioned polyurethane belt cleaner.
- Hydraulic feed in height adjustment.
- Hydraulic fold over for transport.
- Rosta scraper.
- 40 degree rollers.
- Variable speed conveyor via engine speed.
- Feedboot with removable 6mm steel wear liners.

APPLICATIONS



Aggregate

Sand & gravel
Blasted rock
River rock



Recycling

C&D waste
Foundry waste



Mining

Processed ores
Processed minerals



CT-80 TRACKED CONVEYOR



↓ FEEDBOOT

Standard Feedboot Capacity:	0.6 m ³ (0.8yd ³)
Feed in Width:	1300mm (4' 3")
Extended Feedboot Capacity:	1.6m ³ (2.1yd ³)
Extended Feed in Width:	1850mm (6' 1")
Standard Min Feed Height @24°:	1336mm (4' 6")
Extended Min Feed Height @24°:	1634mm (5' 4")

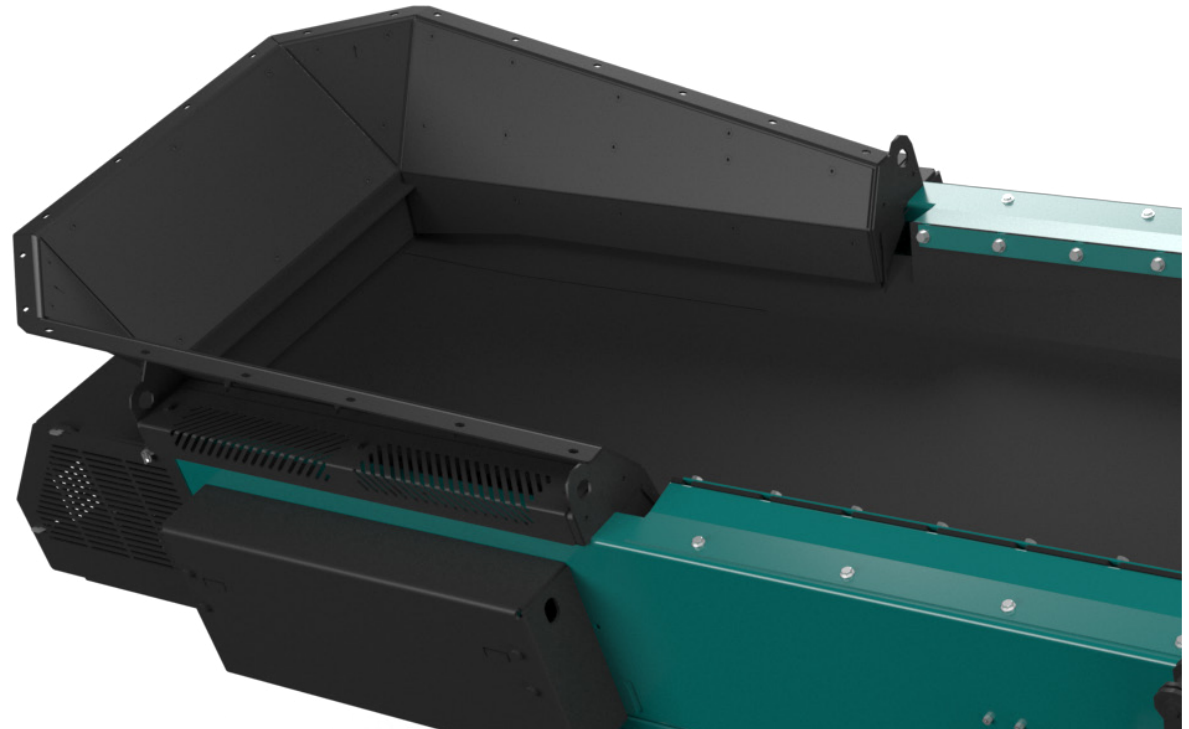



CT-80 TRACKED CONVEYOR



DISCHARGE CONVEYOR

Width:	1050mm (42")
Belt Centres:	22.8m (74' 10")
Belt Type:	Plain
Belt Spec:	EP400 3 4+2
Drive Drum Dia:	286mm (11.3")
Tail Drum Dia:	270mm (10.6")
Max Belt Speed:	136m/m
Motor Size:	800cc
Operating Angle:	5° - 25°
Discharge Height @18°:	8.34m (27' 4")
Stockpile Capacity @18° & 37° Angle of Repose:	1070m ³ (1399 Cu.Yd)
Discharge Height @25°:	10.41m (34' 1")
Stockpile Capacity @25° & 37° Angle of Repose:	2080m ³ (2721 Cu.Yd)
Variable Speed:	Yes via engine speed





CT-80 TRACKED CONVEYOR



↓ TRACKS

Shoe Width:	400mm (1' 4")
Sprocket Centre:	4000mm (13' 1")
Gradability:	30°
Speed:	0.9km/h
Speed High:	1.6km/h





CT-80 TRACKED CONVEYOR



↓ POWER UNIT & HYDRAULICS

Engine (Tier 3): Deutz D2011 L041
Power Rating: 36.4kW (48hp)
RPM: 2200rpm
Crankshaft Pump: 27/27

Engine (Stage V): Deutz TD 2.9 L4
Power Rating: 45kW (60hp)
RPM: 2200rpm
Crankshaft Pump: 27/27

Engine (Tier 4F): Deutz TD 2.9 L04
Power Rating: 45kW (60hp)
RPM: 2200rpm
Crankshaft Pump: 27/27

Diesel Tank Capacity: 200L (53 US GAL)
Hydraulic Tank Capacity: 260L (69 US GAL)





CT-80 TRACKED CONVEYOR



OPTIONS

- 6mm AR400 steel wear feedboot liners
- 20mm rubber wear feedboot liners
- Feedboot extension c/w steel wear liners
- Feedboot extension c/w 20mm rubber wear liners
- Feedboot extension c/w 6mm AR400 steel wear liners
- Impact bed at feedboot area
- Impact rollers at feedboot area
- Large capacity biomass hopper (including landing legs and full length impact bed)
- Blade type / primary scraper
- Conveyor fitted with chevron belt EP315/3 Ply x 3 + 1.5 covers
- Conveyor fitted with heavy duty plain belt EP500 4 ply x 8+2 covers
- Conveyor under guard length of mid-section
- Conveyor head drum guarding
- Conveyor dust covers
- Conveyor water dust suppression (spray bar only)
- Conveyor full length skirting rubber
- Powerunit c/w hydraulic oil, Century 100 - (Recommended for ambient temperatures between +15 to +50°C)
- Radio remote control for tracking only
- Pull cord emergency stop to control panel side or non-control panel side
- Overband magnet option complete with hydraulic kit and support frames
- Twin hydraulic drive discharge conveyor
- Hybrid complete with electric drive conveyor
- Twin electric drive 2 x 11kW motors (400tph max) - hydraulic conveyor drive removed
- Anti-rollback flaps





CT-80 TRACKED CONVEYOR



DIMENSIONS

Figure 1: Powerscreen CT-80
Working Position - Low feed with hopper extension

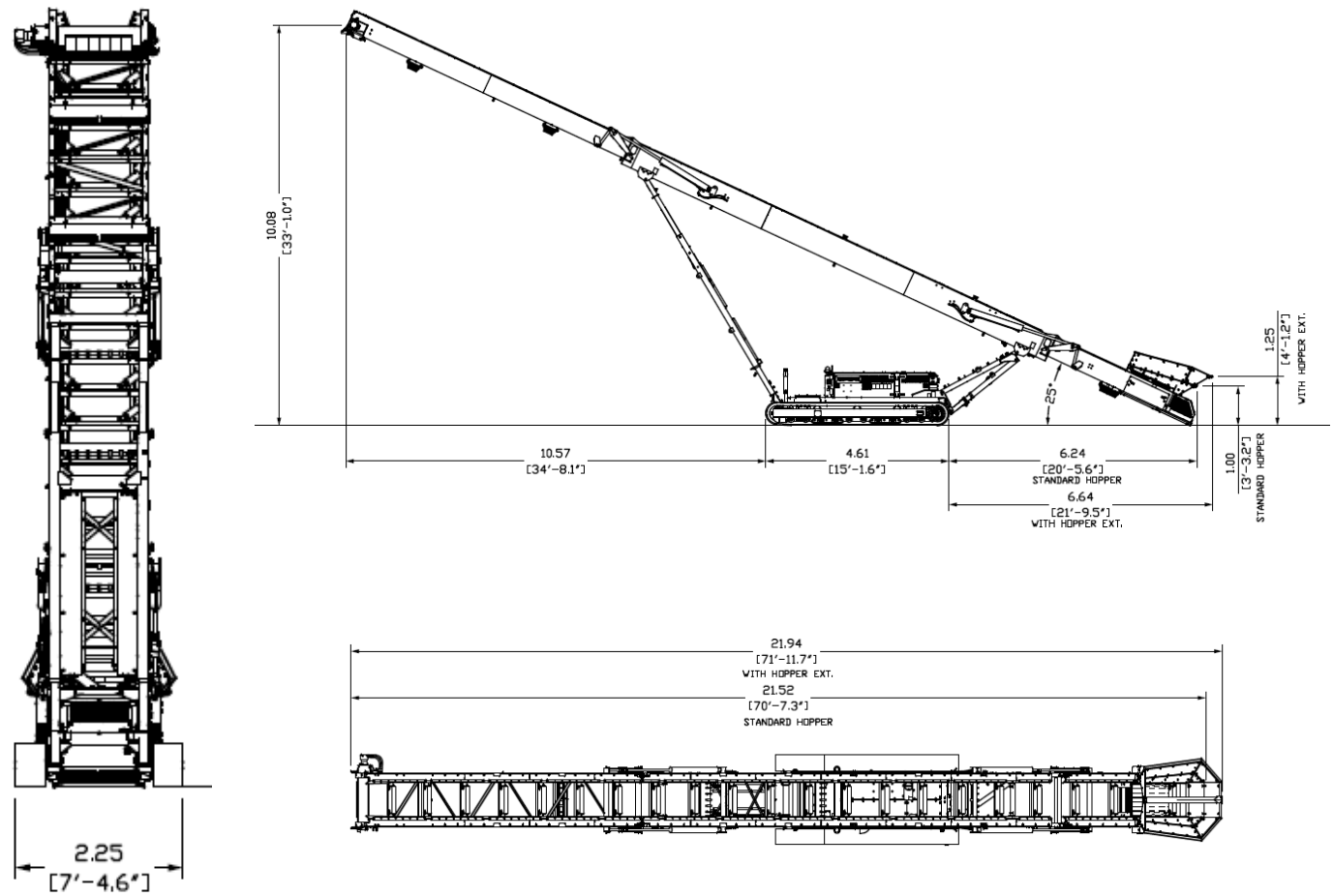

[MORE DIMENSIONS OVERLEAF](#)



CT-80 TRACKED CONVEYOR



DIMENSIONS

Figure 3: Powerscreen CT-80
Transport Position

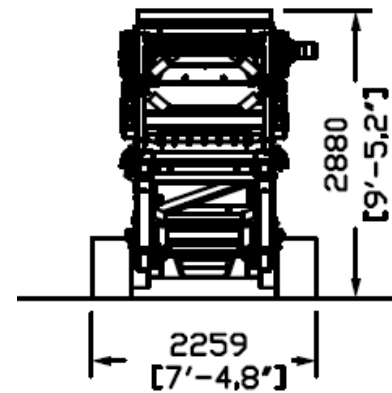
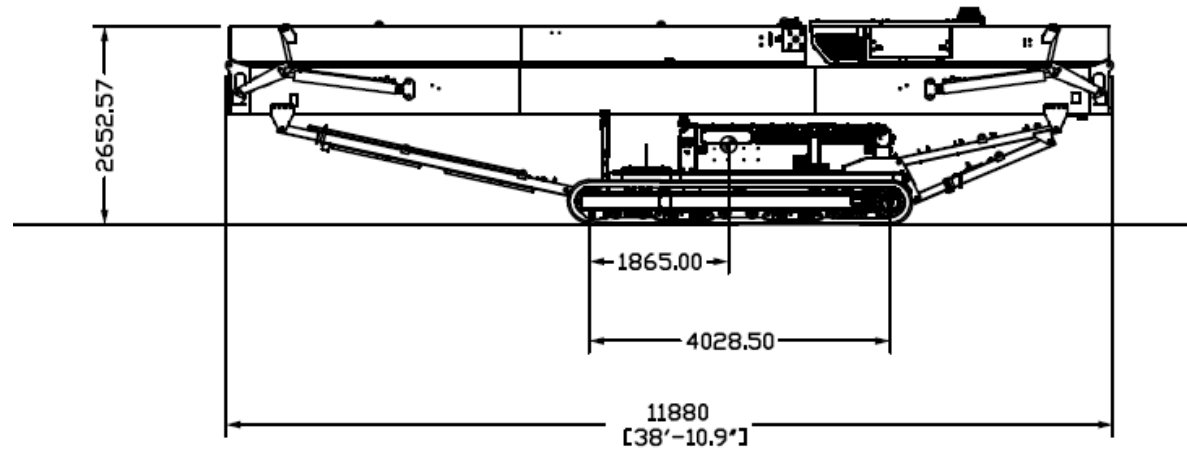



Powerscreen equipment complies with CE requirements.

Please consult Powerscreen if you have any other specific requirements in respect of guarding, noise or vibration levels, dust emissions, or any other factors relevant to health and safety measures or environmental protection needs. On receipt of specific requests, we will endeavour to ascertain the need for additional equipment and, if appropriate, quote extra to contract prices.

All reasonable steps have been taken to ensure the accuracy of this publication, however due to a policy of continual product development we reserve the right to change specifications without notice.

It is the importers' responsibility to check that all equipment supplied complies with local legislation regulatory requirements.

Plant performance figures given in this brochure are for illustration purposes only and will vary depending upon various factors, including feed material gradings and characteristics. Information relating to capacity or performance contained within this publication is not intended to be, nor will be, legally binding.

GET IN TOUCH

Dungannon

200 Coalisland Road, Dungannon,
Co Tyrone, BT71 4DR, Northern Ireland
Tel: +44 (0) 28 87 718 500
Fax: +44 (0) 28 87 747 231

Louisville

11001 Electron Drive,
Louisville, Kentucky, 40299 USA
Tel: +1 502 736 5200
Fax: +1 502 736 5202

