

# POWERSCREEN® CT-100

TRACKED CONVEYOR



TECHNICAL SPECIFICATION - REV 2 01/02/2021





## CT-100 TRACKED CONVEYOR



# OVERVIEW

### SPECIFICATION

|                      |  |
|----------------------|--|
| <b>Total Weight</b>  | 21,800kg (48,061bs)  |
| <b>Transport</b>     | <b>Length</b> 11.9m (39')  |
|                      | <b>Height</b> 3.43m (11' 3")   |
|                      | <b>Width</b> 2.8m (9' 4")  |
| <b>Working @ 24°</b> | <b>Length</b> 28.22m (92' 7")  |
|                      | <b>Height</b> 12.9m (42' 4")   |
|                      | <b>Width</b> 2.8m (9' 4")  |
| <b>Power Unit</b>    | Tier 3: CAT C4.4 83kW (111hp) or,<br>Tier 4F: CAT C4.4 82kW (110hp) or,<br>Stage V: CAT C2.2 55kW (73hp) |
| <b>Plant Colour</b>  | Blue RAL 5021, Grey RAL 7024   |

NOTE: Dimensions may differ slightly from sales drawings due to differences in angles / reference points.

### FEATURES & BENEFITS

- High capacity up to 600tph (661 US tph).
- Maximum feed size up to 150mm (6").
- Eliminates the need for wheeled loaders to create stockpiles - reduces labour and maintenance costs.
- Eliminates the need for handling material multiple times - reduces labour and maintenance costs.
- Improved material quality due to reduced compaction, degradation, segregation and contamination.
- Multiple hopper options available depending on required capacities and operators loading methods or application.
- Rapid set up time and manoeuvrability around site.
- Reduced fuel consumption due to reduced reliance on wheeled loaders.
- Reduced wear on wheeled loaders where a conveyor is utilised.
- Hydraulic folding head section.
- Tensioned polyurethane belt cleaner.
- Hydraulic feed in height adjustment.
- Hydraulic fold over for transport.
- Rosta scraper.
- 40 degree rollers.
- Variable speed conveyor via engine speed.
- Feedboot with removable 6mm steel wear liners.

### APPLICATIONS



#### Aggregate

Sand & gravel  
Blasted rock  
River rock



#### Recycling

C&D waste  
Foundry waste



#### Mining

Processed ores  
Processed minerals



## CT-100 TRACKED CONVEYOR



# ↓ FEEDBOOT

|                                       |  |
|---------------------------------------|--|
| <b>Standard Feedboot Capacity:</b>    | 0.6 m <sup>3</sup> (0.8yd <sup>3</sup> ) |
| <b>Feed in Width:</b>                 | 1300mm (4' 3")                           |
| <b>Extended Feedboot Capacity:</b>    | 1.6m <sup>3</sup> (2.1yd <sup>3</sup> )  |
| <b>Extended Feed in Width:</b>        | 1850mm (6' 1")                           |
| <b>Standard Min Feed Height @24°:</b> | 1013mm (3' 4")                           |
| <b>Extended Min Feed Height @24°:</b> | 1313mm (4' 4")                           |





## CT-100 TRACKED CONVEYOR



# DISCHARGE CONVEYOR

|   |                                 |
|---|---------------------------------|
| <b>Width:</b>   | 1050mm (42'')                   |
| <b>Belt Centres:</b>                                      | 30.1m (98' 9'')                 |
| <b>Belt Type:</b>   | Plain                           |
| <b>Belt Spec:</b>   | EP400 3 4+2                     |
| <b>Drive Drum Dia:</b>                                    | 340mm (13.4'')                  |
| <b>Tail Drum Dia:</b>                                     | 270mm (10.6'')                  |
| <b>Max Belt Speed:</b>                                    | 175m/m                          |
| <b>Motor Size:</b>  | 630cc                           |
| <b>Operating Angle:</b>                                   | 5° - 25°                        |
| <b>Discharge Height @18°:</b>                             | 10.1m (33' 1'')                 |
| <b>Stockpile Capacity @18° &amp; 37° Angle of Repose:</b> | 1900m <sup>3</sup> (2485 Cu.Yd) |
| <b>Discharge Height @25°:</b>                             | 13.1m (43')                     |
| <b>Stockpile Capacity @25° &amp; 37° Angle of Repose:</b> | 4146m <sup>3</sup> (5422 Cu.Yd) |





## CT-100 TRACKED CONVEYOR



# ↓ TRACKS

|                  |                 |
|------------------|-----------------|
| Shoe Width:      | 400mm (1' 4")   |
| Sprocket Centre: | 4000mm (13' 1") |
| Speed:           | 1.1km/h         |
| Speed High:      | 1.9km/h         |





## CT-100 TRACKED CONVEYOR



# POWER UNIT & HYDRAULICS

**Engine (Tier 3):** CAT C4.4  
**Power Rating:** 83kW (111hp)  
**RPM:** 1800rpm  
**Crankshaft Pump:** 33/33cc  
**PTO Pump:** 17cc Aux Pump

**Engine (Tier 4F):** CAT C4.4  
**Power Rating:** 82kW (110hp)  
**RPM:** 1800rpm  
**Crankshaft Pump:** 33/33cc  
**PTO Pump:** 17cc Aux Pump

**Engine (Stage V):** CAT C2.2  
**Power Rating:** 55kW (73hp)  
**RPM:** 2300rpm  
**Crankshaft Pump:** 24/24/10cc

**Diesel Tank Capacity:** 220L (58 US GAL)  
**Hydraulic Tank Capacity:** 400L (106 US GAL)





## CT-100 TRACKED CONVEYOR



## OPTIONS

- 6mm AR400 steel wear feedboot liners
- 20mm rubber wear feedboot liners
- Feedboot extension c/w steel wear liners
- Feedboot extension c/w 20mm rubber wear liners
- Feedboot extension c/w 6mm AR400 steelwear liners
- Impact rollers at feedboot area
- Anti-rollback flaps
- Twin drive motors on discharge conveyor
- Blade type / primary scraper (plain belt only)
- Conveyor fitted with chevron belt EP315/3 Ply 3 + 1.5 covers
- Conveyor fitted with heavy duty plain belt EP500 4 ply x 8+2 covers
- Conveyor under guard length of mid-section
- Conveyor head drum guarding
- Conveyor dust covers
- Conveyor water dust suppression (spray bar only)
- Conveyor full length skirting rubber
- Powerunit c/w hydraulic oil, Century 100 - (Recommended for ambient temperatures between +15 to +50°C)
- Radio remote control for tracking
- Pull cord emergency stop on either control panel or non-control panel side of machine
- Overband magnet option complete with hydraulic kit and support frames





# DIMENSIONS

## CT-100 TRACKED CONVEYOR



Figure 1: Powerscreen CT-100  
Working Position

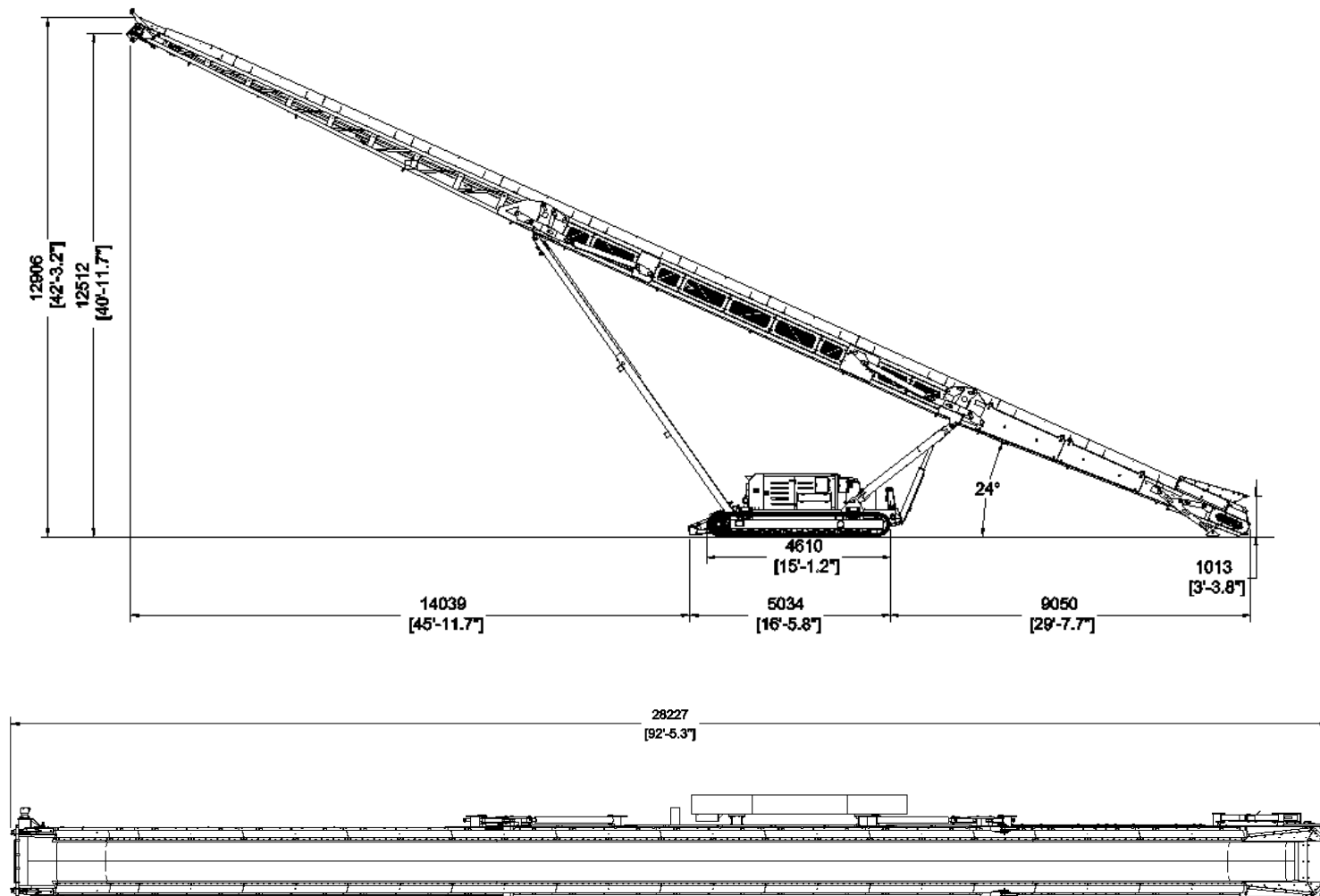

MORE DIMENSIONS OVERLEAF



## CT-100 TRACKED CONVEYOR



# DIMENSIONS

Figure 2: Powerscreen CT-100  
Working Position

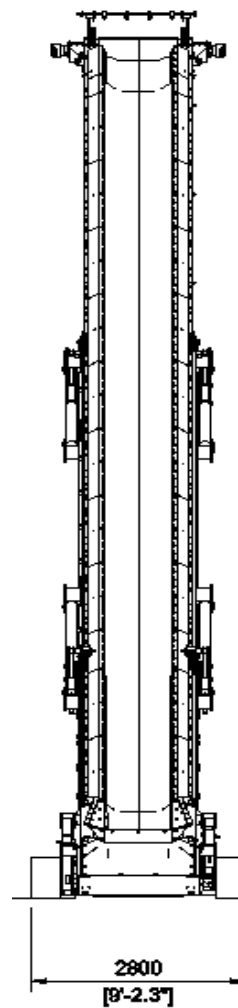

MORE DIMENSIONS OVERLEAF



## DIMENSIONS

### CT-100 TRACKED CONVEYOR



Figure 3: Powerscreen CT-100  
Transport Position

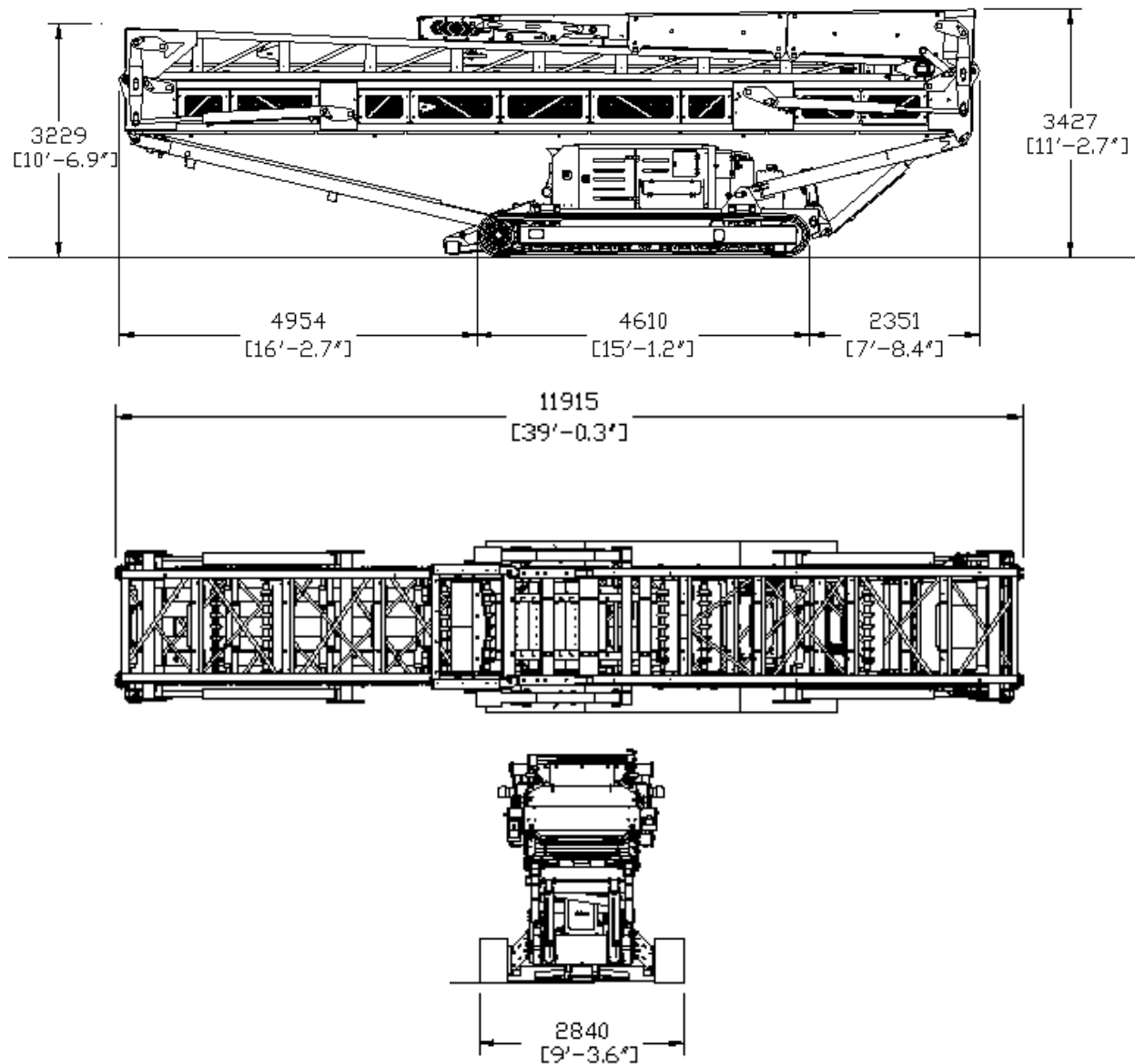



### **Powerscreen equipment complies with CE requirements.**

Please consult Powerscreen if you have any other specific requirements in respect of guarding, noise or vibration levels, dust emissions, or any other factors relevant to health and safety measures or environmental protection needs. On receipt of specific requests, we will endeavour to ascertain the need for additional equipment and, if appropriate, quote extra to contract prices.

All reasonable steps have been taken to ensure the accuracy of this publication, however due to a policy of continual product development we reserve the right to change specifications without notice.

It is the importers' responsibility to check that all equipment supplied complies with local legislation regulatory requirements.

Plant performance figures given in this brochure are for illustration purposes only and will vary depending upon various factors, including feed material gradings and characteristics. Information relating to capacity or performance contained within this publication is not intended to be, nor will be, legally binding.

## **GET IN TOUCH**

### **Dungannon**

200 Coalisland Road, Dungannon,  
Co Tyrone, BT71 4DR, Northern Ireland  
Tel: +44 (0) 28 87 718 500  
Fax: +44 (0) 28 87 747 231

### **Louisville**

11001 Electron Drive,  
Louisville, Kentucky, 40299 USA  
Tel: +1 502 736 5200  
Fax: +1 502 736 5202

