

# POWERSCREEN® TRAKPACTOR 260

HORIZONTAL IMPACTOR



TECHNICAL SPECIFICATION - REV 7 01/01/2022





## TRAKPACTOR 260



# OVERVIEW

### SPECIFICATION

<b>Total Weight</b>	Tier 3: 26,350kg (58,092lbs) Bypass conveyor, twin pole magnet Tier 4F: 25,750kg (56,769lbs) Bypass conveyor, twin pole magnet (heavy duty)
<b>Transport</b>	<b>Length</b> 13.5m (44' 4") <b>Height</b> 3.2m (10' 6") <b>Width</b> 2.5m (8' 3")
<b>Working</b>	<b>Length</b> 13.43m (44' 1") <b>Height</b> 3.34m (11' 3") <b>Width</b> 3.93m (12' 11")
<b>Crusher Type:</b>	Twin apron 4 bar impact crusher, feed opening 860mm x 610mm (34" x 24")
<b>Power Unit</b>	Tier IIIA Caterpillar C7.1 ACERT 186kW (250hp) or Tier 4F/Stage V Caterpillar C7.1 205kW (275hp)
<b>Plant Colour</b>	RAL 5021, RAL 7024, RAL 9005

### FEATURES & BENEFITS

The Powerscreen® Trakpactor 260 Horizontal Shaft Impactor, is a highly compact tracked crusher designed to offer both excellent reduction & high consistency of product yield. The Powerscreen® Trakpactor 260 is designed mainly for the recycling & demolition markets & is an ideal contractor machine due to its compact design & mobility.

- Output potential of up to 250 tph / 275 US tph - depending on material type & crusher settings
- Suitable for a variety of feed materials
- Radio remote control as standard
- Ideal for recycling & demolition applications
- Replaceable tine bar cartridge style grizzly feeder
- Load management system to control feeder speed
- Proven Terex impact crusher with hydraulic overload protection, 4 bar rotor & twin aprons
- Crusher speed variation through user friendly PLC control system
- Fully independent under crusher vibrating pan feeder (optional)
- HPTO clutch & highly fuel efficient direct drive system
- Modular conveyor with raise/lower facility to aid clearance of rebar
- Overband magnet (optional)
- Powerscreen Pulse telemetry as standard

### APPLICATIONS



**Aggregate**  
Blasted rock  
River rock



**Recycling**  
C&D waste  
Foundry waste



**Mining**  
Processed ores  
Processed minerals



## TRAKPACTOR 260



# ↓ CRUSHER

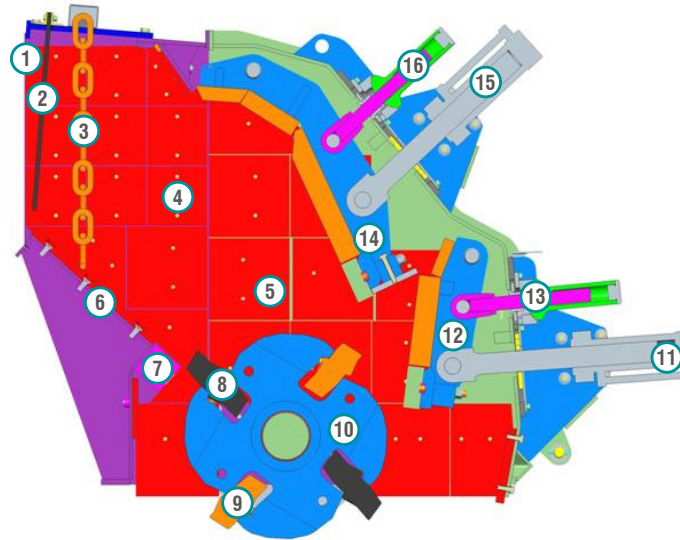

### PRINCIPAL COMPONENTS

- |                    |                              |
|--------------------|------------------------------|
| 1: Crusher Opening | 10: Rotor                    |
| 2: Rubber Curtain  | 11: Control Cylinder         |
| 3: Chain Curtain   | 12: Bottom Impact Apron      |
| 4-5: Wear Liners   | 13: Apron Adjustment Spindle |
| 6: Inlet Chute     | 14: Top Impact Apron         |
| 7: Inlet Wear Bar  | 15: Control Cylinder         |
| 8: Full Blow Bar   | 16: Apron Adjustment Spindle |
| 9: Half Blow Bar   |                              |

### PRINCIPLES OF OPERATION

Material enters via the crusher opening & slides down the inlet chute where it is struck by the blow bar which is held within the rotor. This initial impact breaks the material which is then accelerated onto the top apron where more reduction takes place on impact. This material then falls back into the blow bars & the cycle repeated until the material is small enough to pass between the apron & the blow bar. Once through this gap, further reduction occurs on the bottom apron until the material

can again pass through the gap & discharge from the underside of the crusher.

Any un-crushable material entering the chamber will relieve the overload cylinders & allow the material to pass. The cylinders will then return to the pre-set crushing position. The pre-set gap is adjusted by turning the adjustment spindle whilst the weight of the apron is held on the cylinder (hydraulic assist).

The hydraulic cylinders are pre-loaded to minimise apron bounce & wear on the cylinders. This arrangement also greatly reduces the oversize produced & is Patented: GB2455203



## TRAKTRACTOR 260



# CRUSHER SPECIFICATION

<b>Feed opening:</b>	860mm x 610mm (34" x 24")
<b>Max lump size*:</b>	400mm <sup>3</sup> (16in <sup>3</sup> ) / 700mm (28") diagonally / 750 x 450 x 200mm (30 x 18 x 8") slab *depending on material & blow bar specification
<b>Rotor width:</b>	830mm (33")
<b>Rotor diameter:</b>	860mm (34")
<b>Number of aprons:</b>	2
<b>Max clearance:</b>	165mm (6.5") upper apron, 120mm (4.7") lower apron
<b>Max OSS setting:</b>	120mm (4.7") upper apron, 40mm (1.6") lower apron
<b>Min CSS setting:</b>	50mm (2") upper apron, 20mm (0.75") lower apron
<b>Blow bars:</b>	Total of 4 blow bars
<b>Blow bar removal:</b>	Horizontally
<b>Blow bar configuration:</b>	2 full & 2 half (optional 4 full)
<b>Setting adjustment:</b>	Hydraulic assist
<b>Overload protection:</b>	Hydraulic
<b>Rotor speeds:</b>	700 - 930rpm (32 - 40 m/s 105—131ft/s)
<b>Applications:</b>	Demolition / recycling / quarry
<b>Crusher weight:</b>	6400kg (14,100lbs)
<b>Full blow bar weight:</b>	140kg (309lbs)
<b>Side liners:</b>	20mm (thick, abrasive resistant steel)

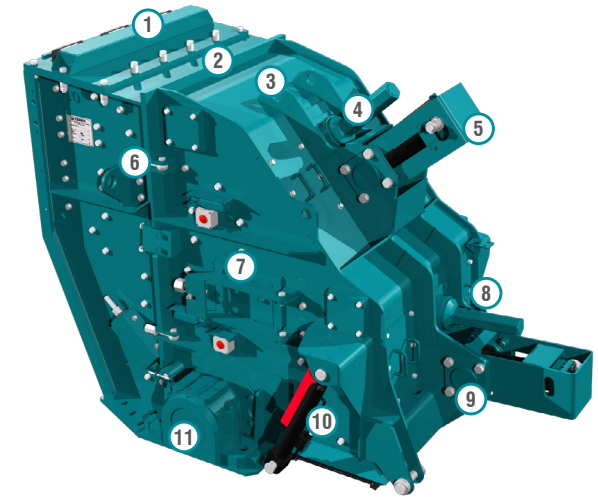

### PRINCIPAL COMPONENTS

- 1: Chain curtain cover
- 2: Main welded body
- 3: Impactor hinged section
- 4: Inspector covers
- 5: Hydraulic overload & adjustment cylinders
- 6: Toggle bolts
- 7: Side door
- 8: Inspection covers
- 9: Trunions
- 10: Hinged section opening cylinder
- 11: Bearings



## TRAKPACTOR 260



# CRUSHER FEATURES

- Crusher body:** Fabricated from steel plate & fully lined with replaceable abrasion resistant liner plates. Hinged side door allows access to apron tips & rotor for gap measurements & inspection. Complete hinged section opens hydraulically to allow blow bar removal & replacement, apron & liner replacement or major maintenance.
- Rotor:** Cast steel fitted with 4 reversible & replaceable blow bars
- Bearings:** Double row self aligning spherical roller bearing fitted each end of rotor
- Aprons:** Cast steel aprons with replaceable abrasion resistant wear plate on tip of bottom apron
- Drive:** Direct through wedge belts with tensioning system on the power unit
- Lubrication:** Grease filled rotor bearings fitted with inner & outer labyrinth seals
- Blow bars:** Standard blow bar is martensitic steel, options are available in martensitic ceramic, medium chrome, medium chrome ceramic, high chrome, high chrome ceramic & toughened chrome.

## APPLICATIONS

This plant is designed for both demolition & quarrying applications. When fitted with martensitic or ceramic blow bars the crusher will tolerate small quantities of steel reinforcing bar in the feed. However, the machine is not designed to accept large pieces of steel or other un-crushable objects, & the feed material should be assessed / inspected for suitability prior to crushing. It is vitally important that large pieces of steel or similar un-crushable objects are not allowed to enter the crushing chamber as severe damage & injury may occur.

When high chrome bars are fitted, **all** steel should be removed from the feed material & the machine should only be used on quarry applications, or clean materials such as asphalt.

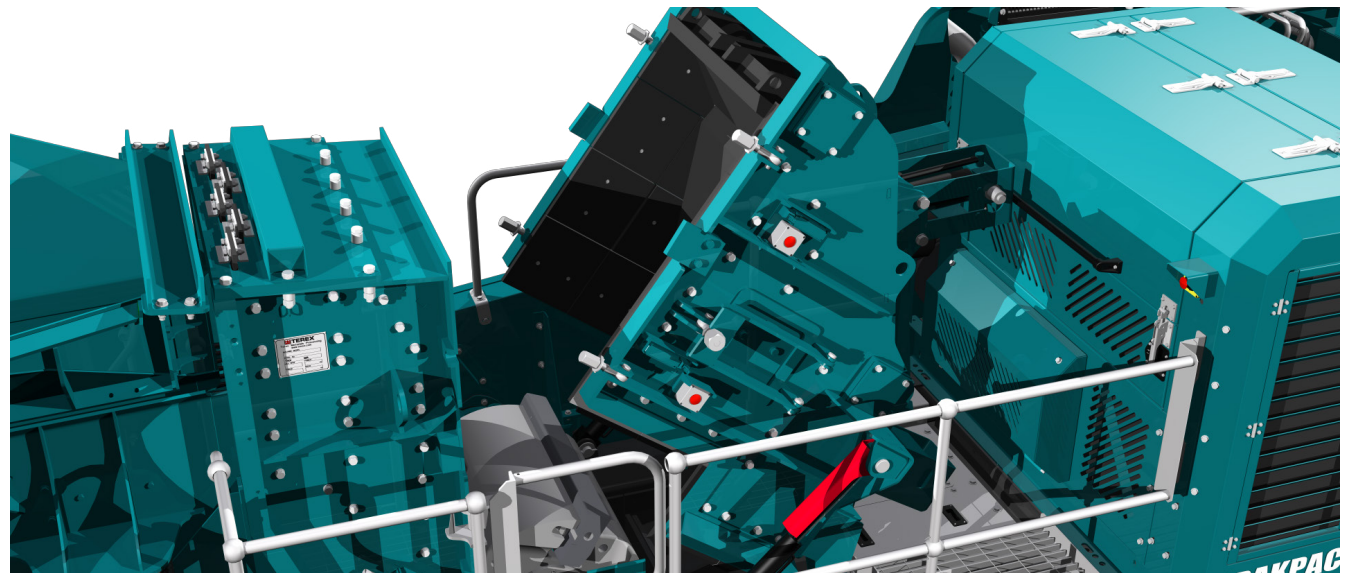



## TRAKPACTOR 260



# ↓ HOPPER

Fixed feed hopper with integral legs, mounted direct to chassis

- Hopper width:** 2.26m (7' 5")
- Hopper capacity:** Up to 2.3m<sup>3</sup> (3 cu. yd. )
- Loading height:** 3.2m (10'6")
- Hopper body:** 8mm thick abrasion resistant steel plate

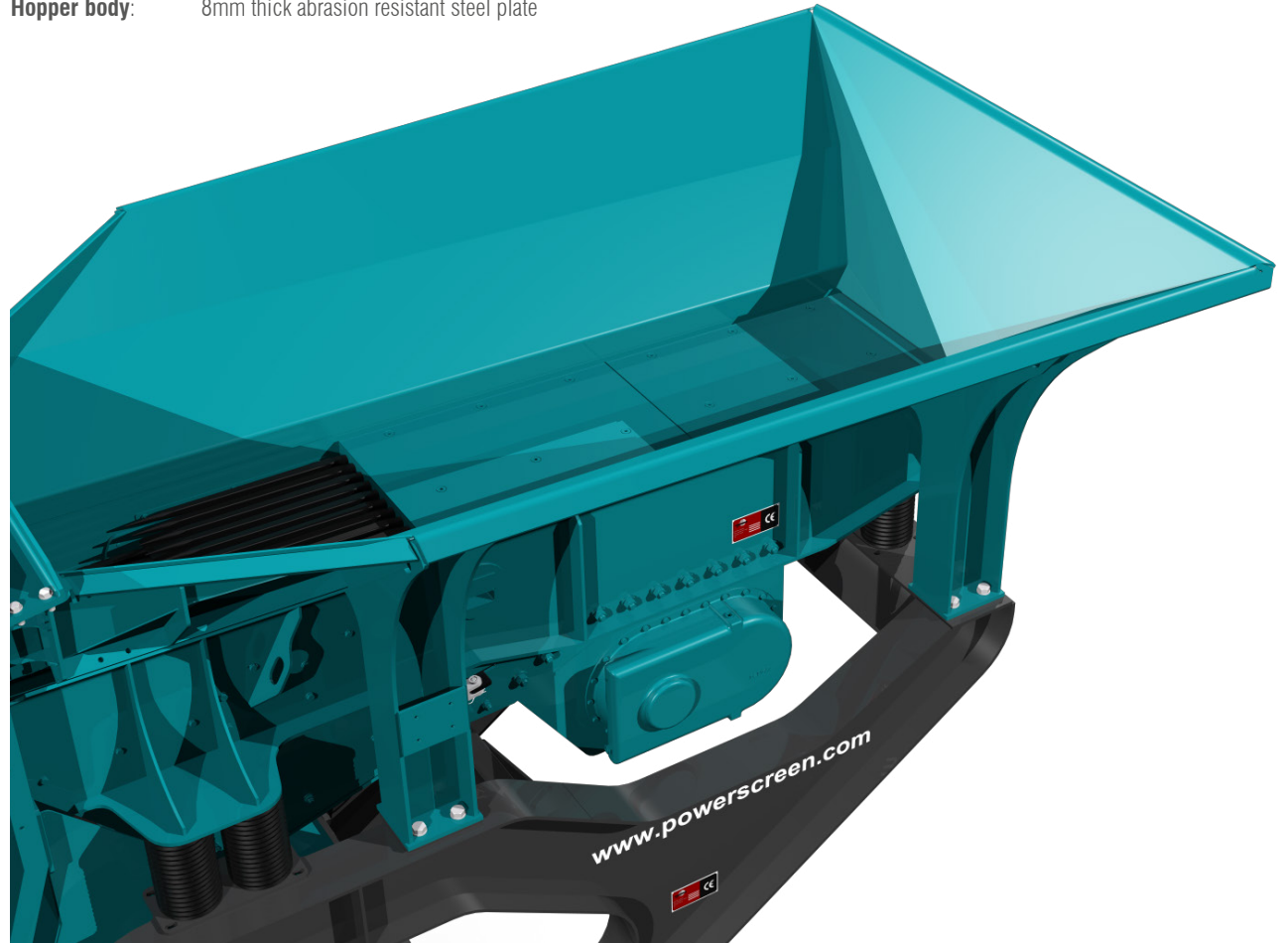



## TRAKPACTOR 260



# VIBRATING GRIZZLY FEEDER

Vibrating grizzly feeder pan with integral two step tine bar grizzly section, extremely efficient & self cleaning

<b>Type:</b>	Sprung vibrating pan
<b>Vibrating unit:</b>	Twin heavy duty cast eccentric shafts running in spherical roller bearings, gear coupled at drive end
<b>Length:</b>	3.27m (10' 9")
<b>Width:</b>	800mm (2' 7")
<b>Pan:</b>	10mm thick fully welded base plate with 10mm thick abrasion resistant liners
<b>Drive:</b>	Flange mounted hydraulic motor

<b>Grizzly:</b>	Two stepped sections with 680mm (2' 3") long tines spaced at 25mm (1") nominal spacing. Front sections with 35mm or 46mm apertures are optional, as are rubber mats to blank over the grizzly sections.
<b>Underscreen:</b>	Removable rubber blanking mat fitted as standard. Mesh screens optional
<b>Control:</b>	Variable speed control through control panel & radio remote option if fitted
<b>Chute:</b>	The plant is fitted with a bypass chute. This has an internal two way flap door to control the direction of fines, either forward onto the product belt or onto the optional side conveyor

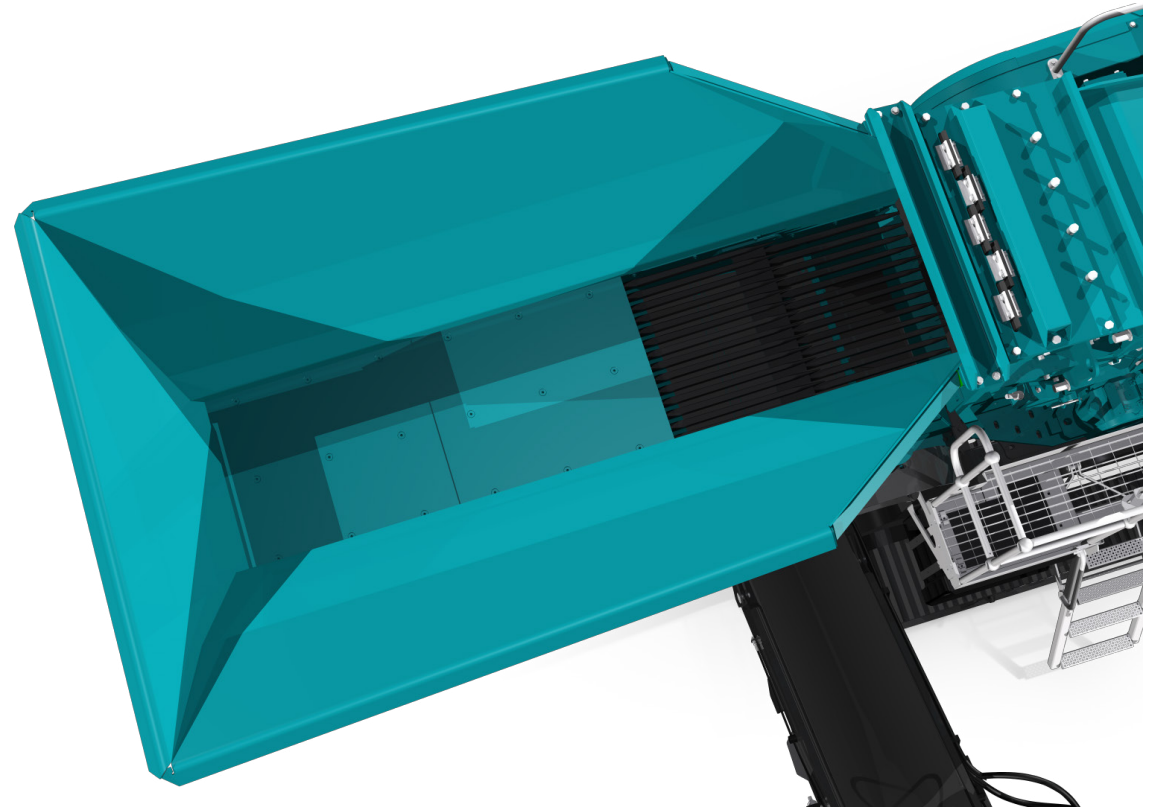



## TRAKTRACTOR 260



# PRODUCT CONVEYOR

## FULL LENGTH PRODUCT CONVEYOR

- Conveyor type:** Full length non-folding main conveyor with impact bars at feed point. Main conveyor can be lowered hydraulically for maintenance
- Belt type:** EP500/3 8+2
- Belt width:** 900mm (36")
- Discharge height:** 3.25m (10' 8") in fully raised position
- Stockpile volume:** 63m<sup>3</sup> (82 cu. yd.)
- Feedboot:** Fabricated steel with abrasion resistant steel liners
- Impact area:** Impact bars at feed point
- Drive:** Hydraulic motor direct to head drum
- Dust suppression:** Fitted with hose and spraybars as standard (no pump supplied)
- Option:** Full length product conveyor with folding head section for transport

## DUST SUPPRESSION SYSTEM

Spray bars with atomiser nozzles mounted over the product conveyor feed & discharge points, piped to an inlet manifold for customer water supply.

- Type:** Clean water multi atomising nozzles
- Inlet:** Single point on chassis
- Inlet pressure:** 3 bar (44psi)
- Water supply:** 24 L/min (6.34 G/min)
- Frost protection:** Via system main valves





## TRAKPACTOR 260



# ↓ POWER UNIT & HYDRAULICS

<b>Tier 3 Equivalent:</b>	Caterpillar C7.1 186kW (250hp)	<b>Fuel tank capacity:</b>	400 L (106 US Gal)
<b>Operating rpm range:</b>	1700 - 2100rpm	<b>Hydraulic tank capacity:</b>	350 L (92 US Gal)
<b>Tier 4F / Stage V:</b>	Caterpillar C7.1 205kW (275hp)	<b>Clutch type:</b>	Highly efficient, self-adjusting HPTO 12 dry plate clutch with electro hydraulic operation
<b>Operating rpm range:</b>	1700 - 2100rpm	<b>Crusher drive:</b>	Direct drive via wedge belts, Tier 3 clutch pulley diameter 335mm (13.2") Crusher pulley diameter 800mm (2' 7") Crushing performance can be tuned, by changing engine speed on the PLC without significant loss of engine performance.
<b>Operating conditions:</b>	Ambient temp. +30°C to -5°C (86°F to 23°F) at altitudes up to 2000m (6562ft) above sea level - For applications outside this range please consult with Powerscreen as the plant performance / reliability may be affected.	<b>Drive tensioning:</b>	Manual tensioner pulley
<b>Reductant tank size:</b>	60 L (16 US Gal)		
<b>Plant drive:</b>	High quality tandem pumps driven via engine PTO's		

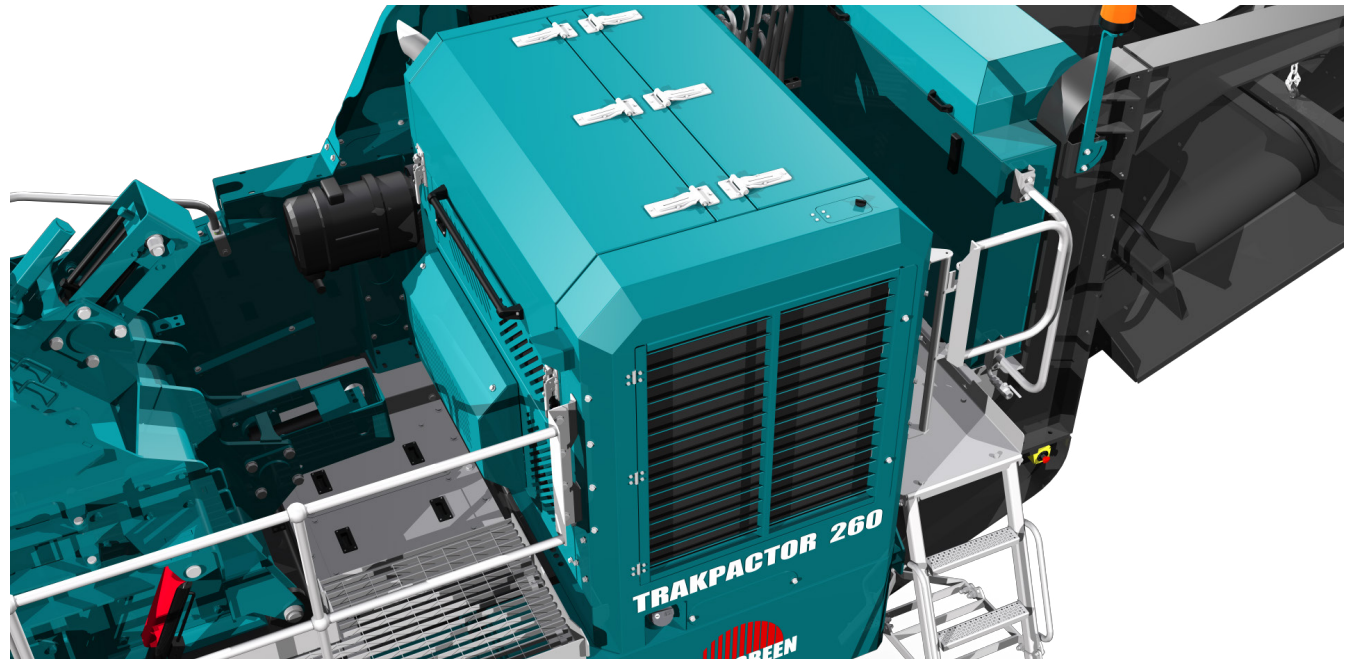



## TRAKPACTOR 260



# ↓ TRACKS

### CRAWLER TRACKS

<b>Type:</b>	Heavy duty, 2 speed, bolt on
<b>Sprocket centres:</b>	2.95m (9' 8")
<b>Track width:</b>	400mm (1'7")
<b>Gradeability:</b>	30° maximum
<b>High speed:</b>	1kph (0.62 mph)
<b>Drive:</b>	Two integral hydraulic motors
<b>Tensioning:</b>	Hydraulic adjuster, grease tensioned





## TRAKPACTOR 260



# PLANT CONTROLS & OTHER

## GUARDS

Wire mesh or sheet metal guards are provided for all drives, flywheels, pulleys & couplings.

The guards provided are designed & manufactured to CE & ANSI standards.

## PLATFORMS

Platforms are provided for maintenance on one side of the feeder & impactor. These are fitted with double row handrails & access ladders.

Platforms are also provided to gain access to the drive side of the crusher & the power unit.

## PLANT CONTROLS

Full PLC control panel

Full system diagnostics

Controls fitted to the plant include:

- Sequential start up
- Engine (start/stop/speed)
- Crusher (start/stop)
- Optional bypass conveyor (start/stop)
- Product conveyor (start/stop & raise/lower)
- Feeder (start/stop/speed) controls, located on the side of the plant

## UMBILICAL CONTROL

An umbilical control unit is supplied with the plant. This is used to control the tracking function & is also fitted with a stop button for the plant.

## CHASSIS

Heavy duty I-Section of welded construction provides maximum strength & accessibility.

## RADIO REMOTE

Complete with integrated tracking functions & plant stop function.

Remote can also be used to:

- Start/stop feeder
- Control feeder speed
- Raise/lower product conveyor
- Open top apron





## TRAKPACTOR 260



# ↓ OPTIONS

### BYPASS CONVEYOR

<b>Conveyor type:</b>	Steel, troughed tray hydraulically folding
<b>Width:</b>	500mm (20")
<b>Discharge height:</b>	1.92m (6'4")
<b>Stockpile volume:</b>	13m <sup>3</sup> (17 cu. yd.)
<b>Drive:</b>	Direct drive hydraulic motor
<b>Lubrication:</b>	Grease points on bearings
<b>Position:</b>	Discharge either side

### MAGNET

<b>Magnet type:</b>	Suspended self cleaning over band with endless belt
<b>Belt width:</b>	750mm (2'6")
<b>Drive:</b>	Direct drive hydraulic motor
<b>Control:</b>	Pre-set variable speed
<b>Discharge:</b>	Via stainless shedder plate
<b>Twin pole:</b>	Also available

### FEEDER UNDERSCREEN MESH

<b>Position:</b>	Removable wire meshes fitted in lieu of standard rubber blanking mat when used in conjunction with optional side conveyor
<b>Size:</b>	10, 20, 30, 40, 50mm

### BLOW BARS

2 full size martensitic & 2 half size manganese blow bars fitted as standard. 2 further options available:

<b>High Chrome:</b>	Suitable for medium to hard rock applications where there is no steel present in feed material. Good wear characteristics
<b>Ceramic:</b>	Suitable for applications with limited steel in feed. Improved wear characteristics over standard martensitic blow bars
<b>4 full blow bars:</b>	Available in all options

### BLOW BAR EXTRACTOR KIT

This is the complete kit (including single acting hydraulic cylinder)  
This is a standalone tool, that can be used to help push the worn blow bars out of the Terex CR004 rotor  
Note: This is a highly recommended piece of kit, especially when working in 'sticky asphalt type applications'.





## TRAKTRACTOR 260



## OPTIONS 2

### HOT/COLD CLIMATE OILS

Cold climate oils - (Recommended for ambient temperatures between -20 to +30°C) - Hydraulic & lubrication oils only. Other component modifications may be required for low temperature operations. Please contact the Powerscreen sales & applications department with any queries.

Hot climate oils - (Recommended for ambient temperatures between +15 to +50°C)

### VIBRATING UNDERPAN FEEDER

**Type:** Steel bodied vibrating feeder fitted with abrasion resistant liners, mounted under crusher & designed to prevent any impact damage to product conveyor

**Width:** 600mm (2')

**Length:** 2m (6' 7")

**Drive:** Hydraulic out of balance exciter

**Width:** 600mm (2')

**Note:** When a vibrating underpan feeder is selected, the short product conveyor belt which accompanies will have the following specification: EP400/3 5+1.5

### BELT WEIGHER

Belt weigher system can be fitted to the product conveyor.

Display: Separate read out near control panel

### FOLDING PRODUCT CONVEYOR

Full length product conveyor with fully folding head section for transport.

### PLANT LIGHTING

Lights mounted over the crusher & on the cowls at the front of the plant. These are directional & are controlled from within the control panel.

### OPTIONAL EXTRAS

- High chrome blow bars
- Ceramic blow bars
- 4 full size hammers in lieu of 2 full & 2 half hammers
- Blow bar extractor kit
- Overband magnetic separator
- Twin pole overband magnetic separator
- Bypass conveyor
- Plant lighting
- Product conveyor hydraulic folding head section
- Feeder underscreen mesh
- Belt weigh
- Underpan feeder





## TRAKPACTOR 260



# ↓ POWERSCREEN PULSE

## RECORD, DISPLAY AND ANALYSE DATA:

HIGH EFFICIENCY THROUGH PRECISE INFORMATION

Available online anywhere and at any time: comprehensive information on the GPS location, start and stop times, fuel consumption, tonnages, cone settings, wear ratings, operating hours, maintenance status, and much more.



  
**AVAILABLE ANYWHERE AND AT ANY TIME**

  
**DASHBOARD DISPLAY**

  
**FLEET OVERVIEW**

  
**WEEKLY REPORT DIRECT TO YOUR INBOX**

  
**GPS: MACHINE TRACKING**

  
**REPORTING UTILISATION, PERFORMANCE & PART SPECIFIC**



## TRAKPACTOR 260



# DIMENSIONS

Figure 1: Trakpactor 260 - VGF & Bypass Conveyor  
Working Position

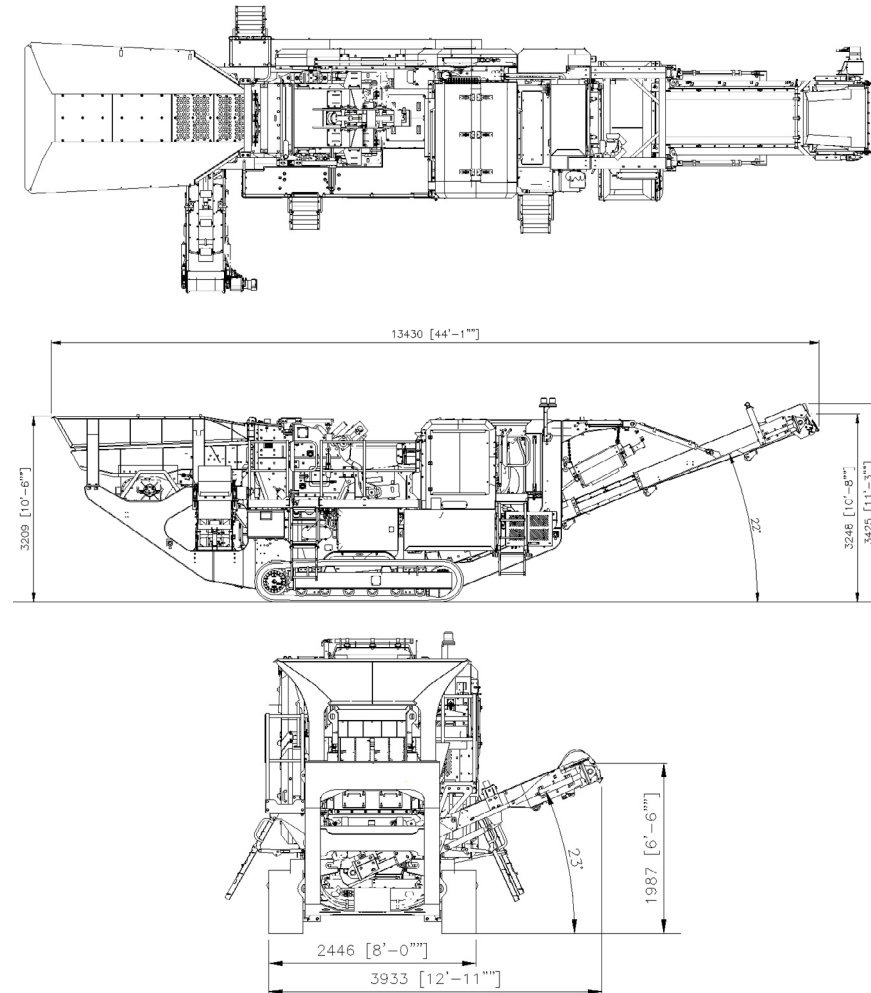

MORE DIMENSIONS OVERLEAF



## TRAKPACTOR 260



# DIMENSIONS

Figure 2: Trakpactor 260 - VGF & Bypass Conveyor  
Transport Position

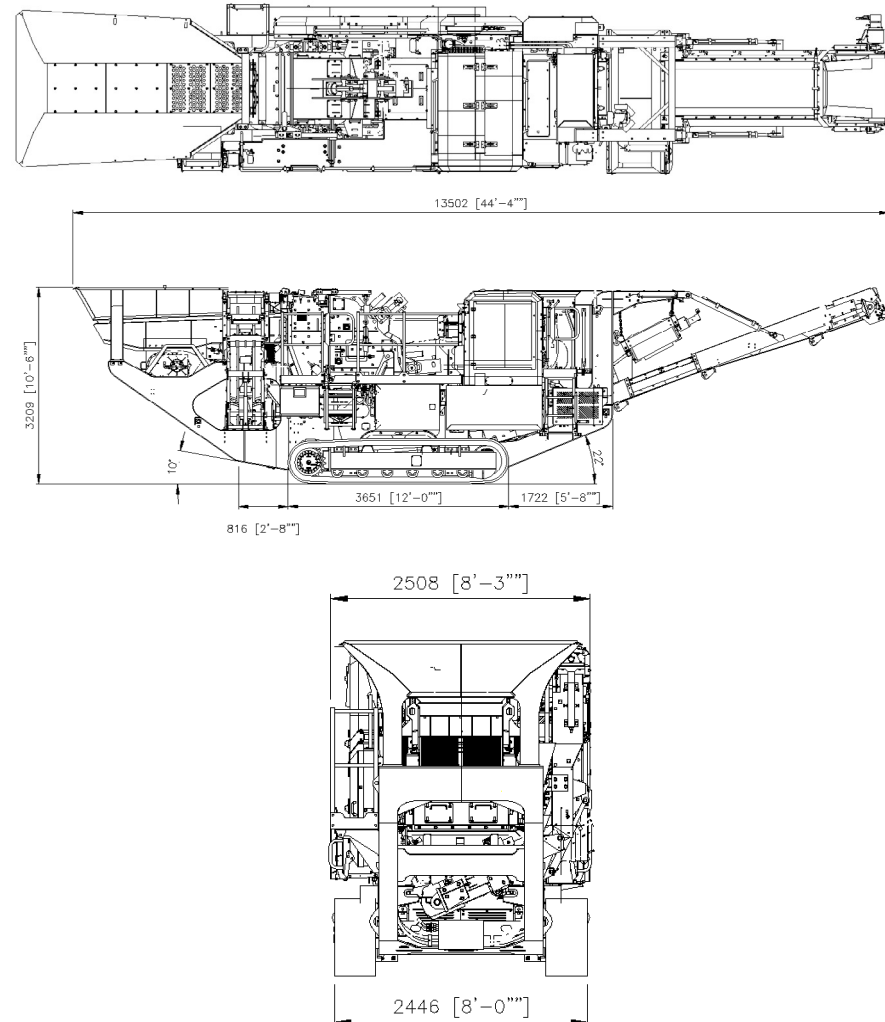



### **Powerscreen equipment complies with CE requirements.**

Please consult Powerscreen if you have any other specific requirements in respect of guarding, noise or vibration levels, dust emissions, or any other factors relevant to health and safety measures or environmental protection needs. On receipt of specific requests, we will endeavour to ascertain the need for additional equipment and, if appropriate, quote extra to contract prices.

All reasonable steps have been taken to ensure the accuracy of this publication, however due to a policy of continual product development we reserve the right to change specifications without notice.

It is the importers' responsibility to check that all equipment supplied complies with local legislation regulatory requirements.

Plant performance figures given in this brochure are for illustration purposes only and will vary depending upon various factors, including feed material gradings and characteristics. Information relating to capacity or performance contained within this publication is not intended to be, nor will be, legally binding.

## **GET IN TOUCH**

### **Dungannon**

200 Coalisland Road, Dungannon,  
Co Tyrone, BT71 4DR, Northern Ireland  
Tel: +44 (0) 28 87 718 500  
Fax: +44 (0) 28 87 747 231

### **Louisville**

11001 Electron Drive,  
Louisville, Kentucky, 40299 USA  
Tel: +1 502 736 5200  
Fax: +1 502 736 5202

