

POWERSCREEN® 1300 MAXTRAK

CONE CRUSHER



TECHNICAL SPECIFICATION - REV 9. 01/01/2019





1300 MAXTRAK CONE



OVERVIEW

SPECIFICATION

Total Weight	Tier 3: 48,020kg (105,866lbs) (No Options) Tier 4F: 47,880kg (105,557lbs) (No Options)
Transport	Length 15.35m (50' 4") Height 3.85m (12' 8") Width 3m (9' 10")
Working	Length 15.50m (50' 10") Height 4.70m (15' 5") Width 3.85m (12' 8")
Crusher Type:	1300 Automax Crusher
Power Unit	Caterpillar C13 ACERT 328 kW (440hp) or Scania DC13 331 kW (450hp)
Paint Colour	RAL 5021, RAL 7024, RAL 9005

FEATURES & BENEFITS

The Powerscreen® 1300 Maxtrak is a medium to large sized track mobile cone crusher, ideally suited to secondary applications such as taking an all in feed from a primary crusher. Based around the 1300 Automax® cone crusher, the plant excels in the production of sub-base or aggregates, providing excellent cubicity, throughput & reduction ratios.

- Output potential of up to 350 tph / 386 US tph - depending on feed material & crusher settings
- Renowned Automax® crusher technology
- Excellent product shape
- High reduction ratio
- Cone feed box level control to maintain choke feeding
- Hydraulic crusher setting
- Cone overload protection
- Metal detector
- Dust suppression system
- Economical to operate with a highly fuel efficient direct drive system
- Heavy duty fabricated chassis & track frame
- Remote control via umbilical

APPLICATIONS



Aggregate
Sand & gravel
Blasted rock
River rock



Recycling
C&D waste
Foundry waste



Mining
Processed ores
Processed minerals



1300 MAXTRAK CONE



CONE CRUSHER

- Crusher type:** 1300 Automax Crusher
- Liners:** Manganese steel alloy mantle & concave
- Standard concave:** Medium Coarse (MC)
- Lubrication:** Pumped system having a chassis mounted lube tank with air blast cooler
- Adjustment:** Hydraulic setting adjustment, automatic overload release & hydraulic unblocking
- Control:** 2 Operating modes available:
 - Autaset Mode: fixed parameters
 - Maxset Mode: load sensing, parameters auto adjust & maximise performance
- Concave options:** 2 Operating modes available:
 - Autaset Mode: Fixed parameters
 - Maxset Mode: Load sensing, parameters auto adjust to maximise performance
- Concave option:** Autosand (AS)
- Drive:** Wedge belt drive from engine via hydraulically controlled clutch

LINER PROFILE	MAXIMUM FEED SIZE	MAXIMUM RECOMMENDED CSS
Medium Coarse	220mm (8.5")	45mm (1.8")
Extra Coarse	260mm (10.2")	45mm (1.8")
Autosand	63mm (2.5")	30mm (1.2")

Each of the above available with choice of long & short throw eccentrics

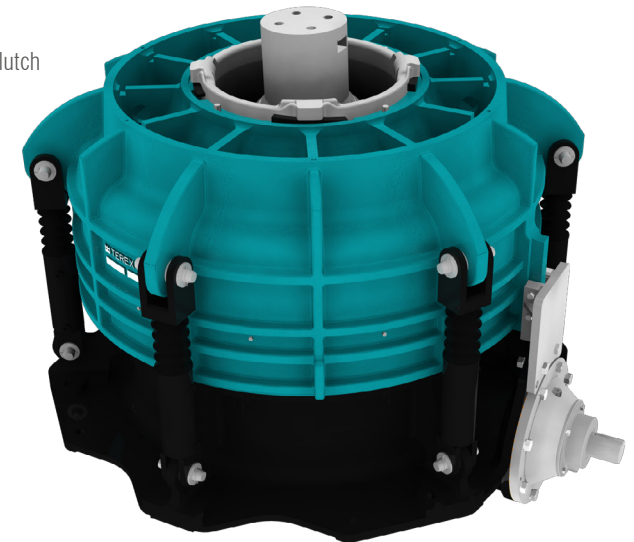

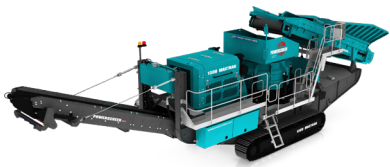

1300 MAXTRAK CONE



HOPPER

- Hopper type:** Fixed feed hopper with direct feed rear door
- Hopper length:** 3.5m (11' 6")
- Hopper width:** 2.8m (9' 2")
- Hopper capacity:** Up to 7m³ (9.1 cu. yd.) gross depending on method of feed
- Hopper body:** Fabricated in 10mm thick wear resistant steel plate, with internal crash bars to minimise impact load on the feed conveyor

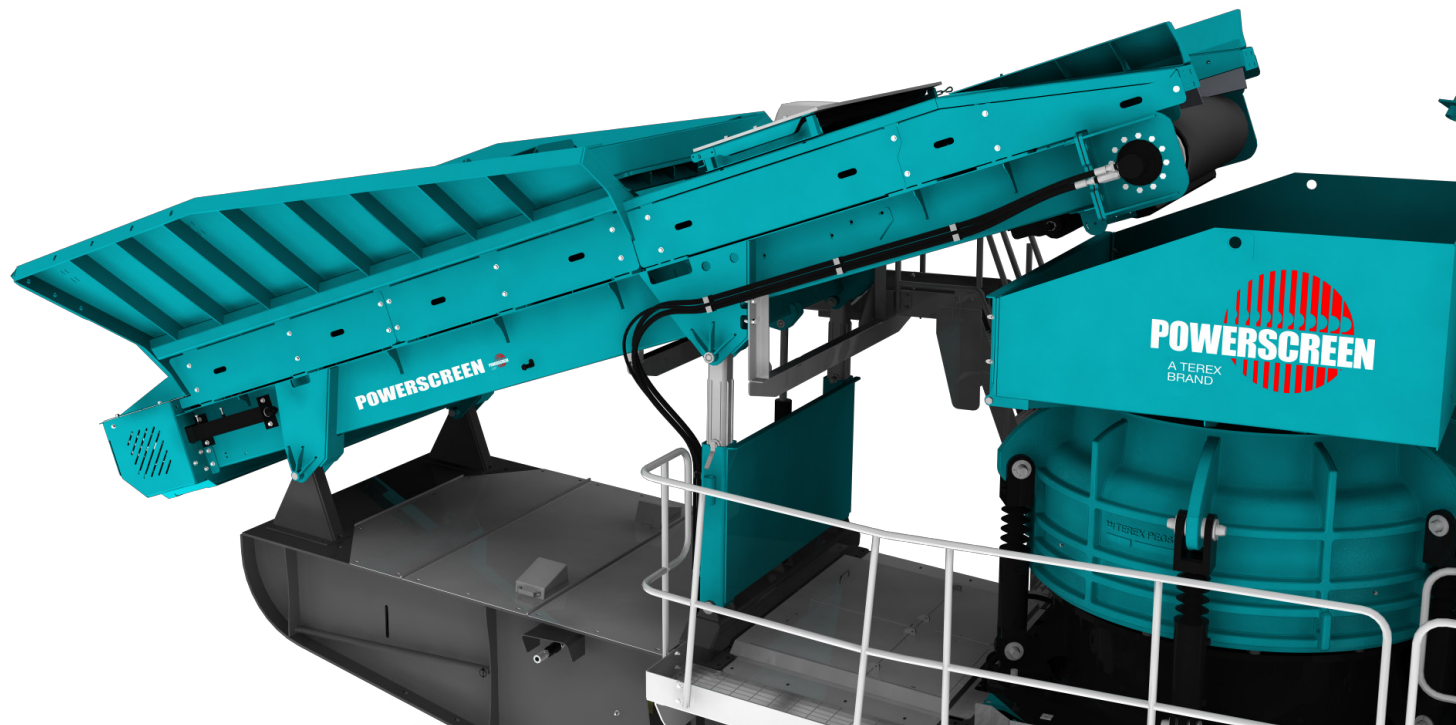



1300 MAXTRAK CONE



↓ FEED CONVEYOR

Conveyor type:	Shallow troughed belt, variable speed
Design:	Raise & lower hydraulically for transport, operation & crusher maintenance
Belt type:	EP630/4 with 6mm top & 2mm bottom heavy-duty rubber covers, vulcanised joint
Belt adjustment:	Screw adjustment at the tail shaft
Belt width:	1300mm (4' 3")
Feed height:	3.22m (10' 7")
Drive:	Hydraulic drive via flange mounted gearbox

Impact rollers:	Below feed hopper
Metal detector:	Suitable for detecting steel & manganese, complete with audible warning device & connected to stop the feed conveyor
Barge boards:	Extend from the feed conveyor to the conveyor head
Lubrication:	Oil lubricated head drum gearbox. Grease nipples for lubrication of shaft bearings
Level probe:	Crusher feed ring fitted with level probe designed to regulate & constantly choke feed the crusher

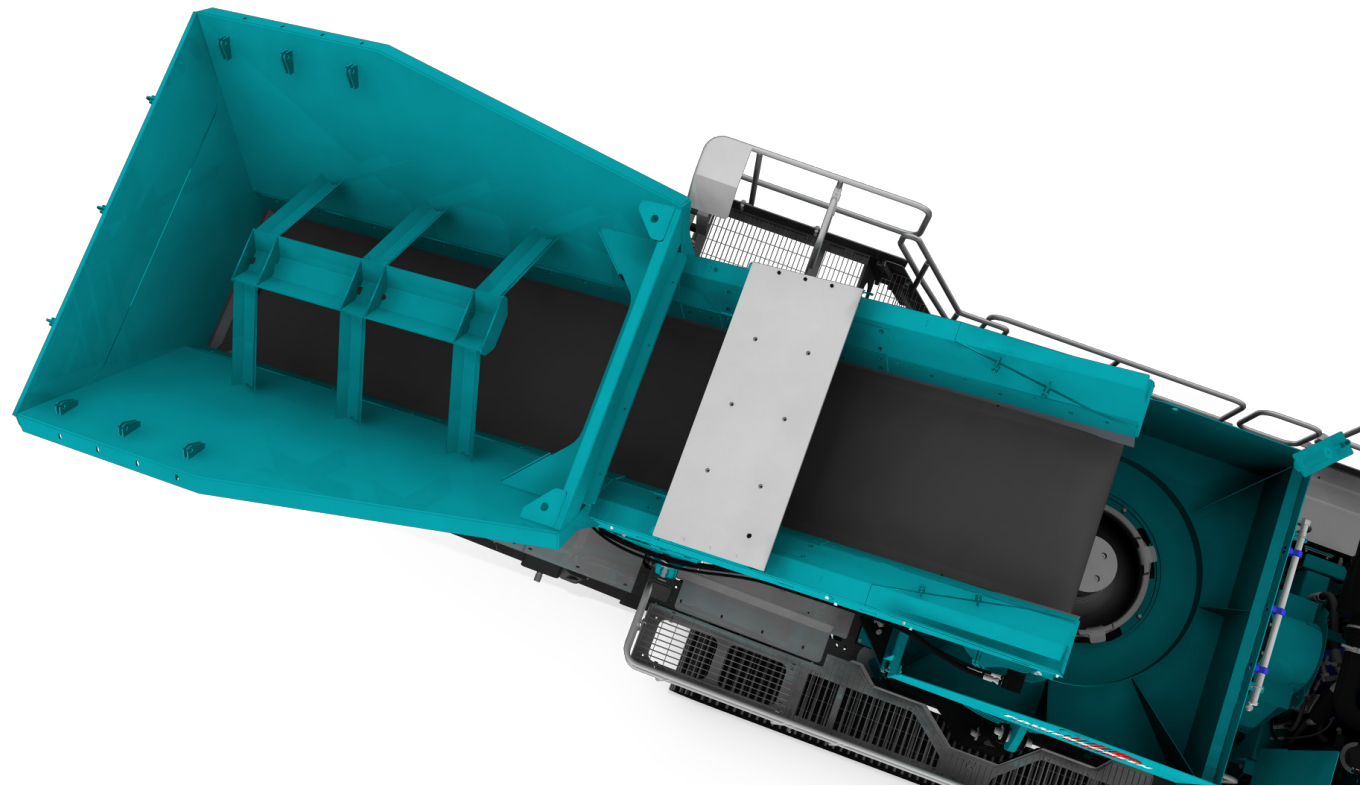



1300 MAXTRAK CONE



PRODUCT CONVEYOR

Conveyor type:	Troughed belt. Fixed speed conveyor with hydraulic drive
Belt type:	EP500/3 with 5mm top & 1.5mm bottom heavy duty rubber covers, vulcanised joint
Belt width:	1000mm (3' 3")
Discharge height:	3.4m (11' 2")
Stockpile volume:	72m ³ (94 cu. yd.)
Impact rollers:	Fitted below the crusher outlet
Skirting:	Fully skirted rubber sealing along the conveyor length
Drive:	Direct drive hydraulic motor
Belt covers:	Canvas type removable dust covers are fitted over the exposed section of the conveyor
Belt adjustment:	Screw adjustment at the head drum
Lubrication:	Grease nipples for lubrication of shaft bearings
Speed sensor:	Designed to stop plant feed when discharge conveyor stops

DUST SUPPRESSION SYSTEM

Spray bars with atomiser nozzles are mounted over the crusher mouth, product conveyor feed & discharge points. Piped to an inlet manifold

Type:	Clean water atomising nozzles
Inlet:	Single point on chassis
Pressure required:	2.8 bar (42 psi)
Frost protection:	Via system drain valves
Pump:	Optional extra

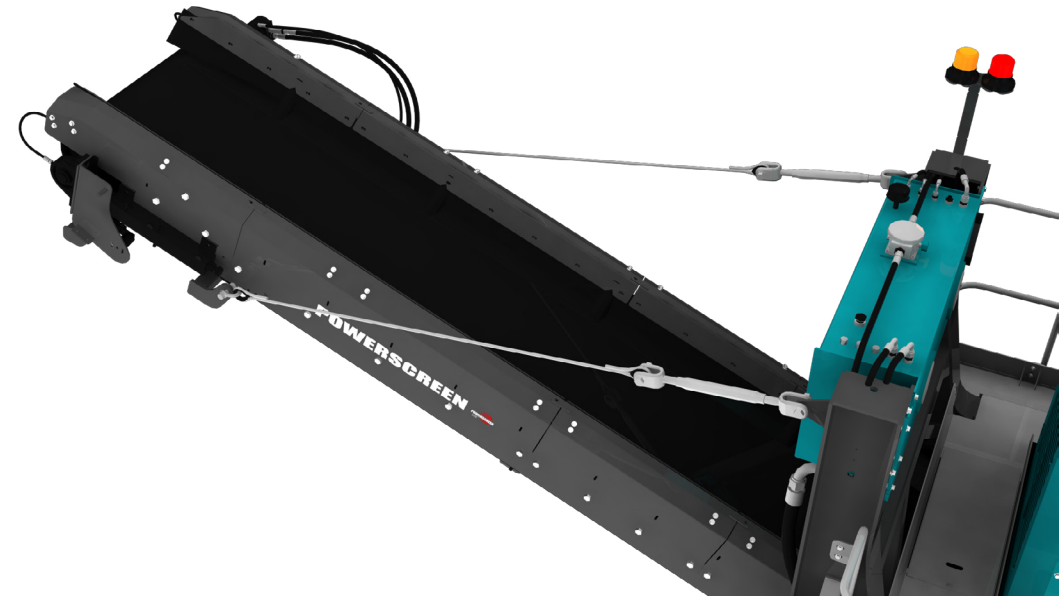



1300 MAXTRAK CONE



↓ POWER UNIT & HYDRAULICS

Tier 3 Equivalent: Caterpillar C-13 ACERT, 328 kW (440hp)

Operating conditions: Ambient temp. +30°C to -5°C (86°F to 23°F) at altitudes up to 2000m (6562ft) above sea level

- For applications outside this range please consult with Powerscreen as the plant performance / reliability may be affected.

Operating rpm range: 1775 - 1825rpm

Plant drive: High quality pumps driven via engine PTOs

Fuel tank capacity: 1000 L (264 US Gal)

Tier 4F/ Stage IV: Scania DC13, 331 kW (450hp)

Operating conditions: Ambient temp. +30°C to -5°C (104°F to 10°F) altitudes up to 2000m (6562ft) above sea level

- For applications outside this range please consult with Powerscreen as the plant performance / reliability may be affected.

Operating rpm range: 1775 - 1825rpm

Emission control technique: Selective Catalytic Reduction (SCR)

Reductant tank size: 60 L (16 US Gal)

Plant drive: High quality pumps driven via engine PTOs

Fuel tank capacity: 1000 L (264 US Gal)

Hydraulic tank capacity: 300 L (79 US Gal)

Cone lube oil tank capacity: 265 L (70 US Gal)

Crusher drive: Direct drive via wedge belts

Crusher drive tensioning: Manually adjustable screw tensioners located under power unit

Clutch type: Highly efficient, self-adjusting HPTO 12 dry plate clutch with electro hydraulic operation

Scania Stage IV / Tier 4 Final Technology

Scania industrial engines meet the requirements of Stage IV and Tier 4 Final without the need for a particulate filter. With only EGR and SCR technology, the installation will be unaffected. Scania-developed systems for engine management and emission control ensure an attractive blend of performance and operating economy.

The function of the SCR system is based on the injection of a urea solution (AdBlue or DEF, Diesel Exhaust Fluid) into the after-treatment system.

With EGR, a small amount of exhaust gases is returned to the intake of the engine, diluting the intake air and reducing the oxygen concentration. This will reduce the combustion temperature and further reduce emissions.





1300 MAXTRAK CONE



TRACKS

Type: Heavy duty bolt on tracks

Sprocket centres: 3800mm (12' 6")

Track width: 500mm (1' 8")

Gradeability: 30° maximum

High speed: 1.1kph (0.7mph)

Drive: Hydraulic

Tensioning: Hydraulic adjuster, grease tensioned





1300 MAXTRAK CONE



PLANT CONTROLS & OTHER

CHASSIS

Heavy duty I-Section welded construction, provides maximum strength & accessibility

CHUTES

Feed box: Fabricated in 6mm mild steel plate. Hinge down back plate to lower feed conveyor head section for transportation.

Product conveyor: Fabricated in 10mm mild steel plate with replaceable 20mm wear resistant liners at impact points.

GUARDS

Wire mesh or sheet metal guards are provided for all drives, flywheels, pulleys & couplings.



PLATFORMS

Platforms are provided for inspection & maintenance, allowing access to each side of the engine and crusher & one side of the feed conveyor head section

All platforms are galvanised as standard & are made from steel flooring with steel toe boards, double row handrails & access ladders

UMBILICAL CONTROL

An umbilical control unit is also supplied with the plant. This is used to control the tracking function & is also fitted with a stop button for the plant

PLANT CONTROLS

PLC control panel

Full system diagnostics & monitoring

Key functions controlled from the panel include:

- Automatic sequential start/stop
- Feed conveyor start/stop
- Feed conveyor speed control
- Crusher level settings
- Crusher CSS control
- Calibration & monitoring of liner wear
- Tracking mode on/off





1300 MAXTRAK CONE



OPTIONS

RADIO REMOTE CONTROL

Complete with integrated tracking functions & plant stop button. NB - Only available in certain countries where type approval has been obtained

Remote can also be used to:
Start/Stop feeder

ELECTRIC REFUELLING PUMP

A 24 volt refuelling pump allows fuel to be drawn from a remote source. Fuel transfer rate of 100 L/min

CONTROL PANEL POSITIVE PRESSURISATION

An additional unit designed to reduce dust particles within the Control Panel.

A continuous flow of clean air is passed through the cabinet whilst the unit simultaneously filters out any particulate laden air.

HOT/COLD CLIMATE OILS

Cold climate oils - (recommended for ambient temperatures between -20 to +30°C) - Hydraulic & Lubrication oils only. Other component modifications may be required for low temperature operations. Please contact the Powerscreen sales & applications department with any queries

Hot climate oils - (recommended for ambient temperatures between +15 to +50°C)



1300 MAXTRAK CONE



OPTIONS 2

OPTIONAL EXTRAS

- Autosand concave
- Feed hopper extensions plates
- Electric refuelling pump
- Product conveyor belt weigher
- Electric refuelling pump
- Camera and viewing screen
- Electric water pump
- Radio remote control
- Hot/cold climate oils
- Control panel positive pressurisation
- Hot climate cooler (lube oil)
- Lighting mast





1300 MAXTRAK CONE



↓ POWERSCREEN PULSE

RECORD, DISPLAY AND ANALYSE DATA:

HIGH EFFICIENCY THROUGH PRECISE INFORMATION

Available online anywhere and at any time: comprehensive information on the GPS location, start and stop times, fuel consumption, tonnages, cone settings, wear ratings, operating hours, maintenance status, and much more.



AVAILABLE ANYWHERE AND AT ANY TIME



DASHBOARD DISPLAY



FLEET OVERVIEW



WEEKLY REPORT DIRECT TO YOUR INBOX



GPS: MACHINE TRACKING



REPORTING UTILISATION, PERFORMANCE & PART SPECIFIC



1300 MAXTRAK CONE



DIMENSIONS

Figure 1: 1300 Maxtrak
Working Position

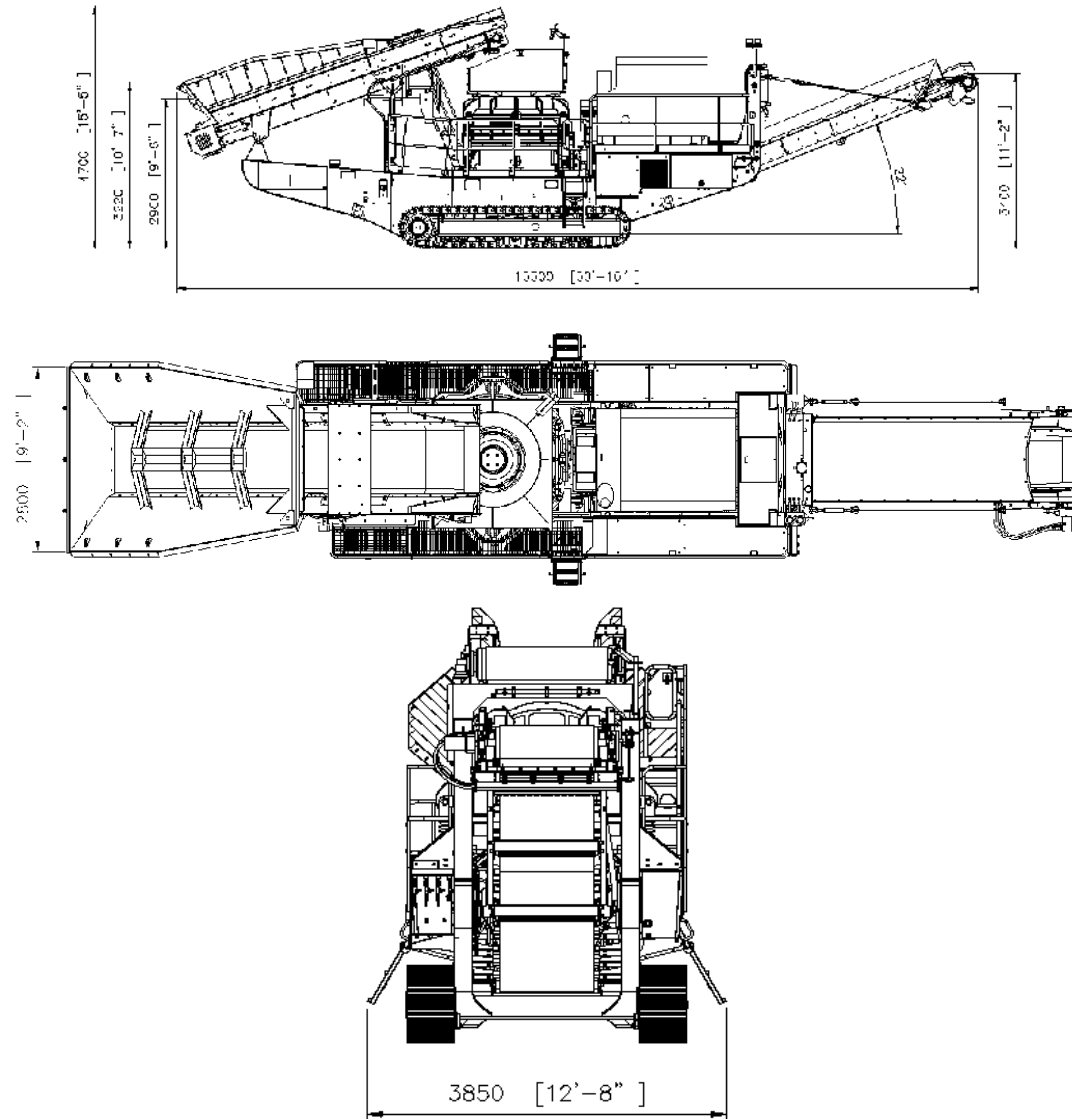

MORE DIMENSIONS OVERLEAF



1300 MAXTRAK CONE



↓ DIMENSIONS

Figure 2: 1300 Maxtrak
Transport Position

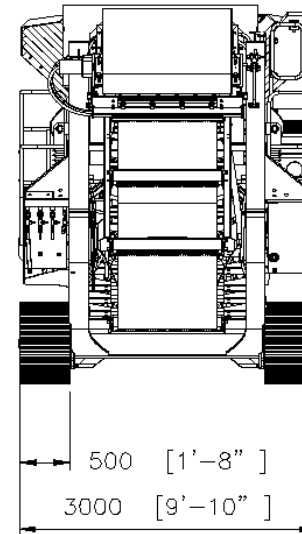
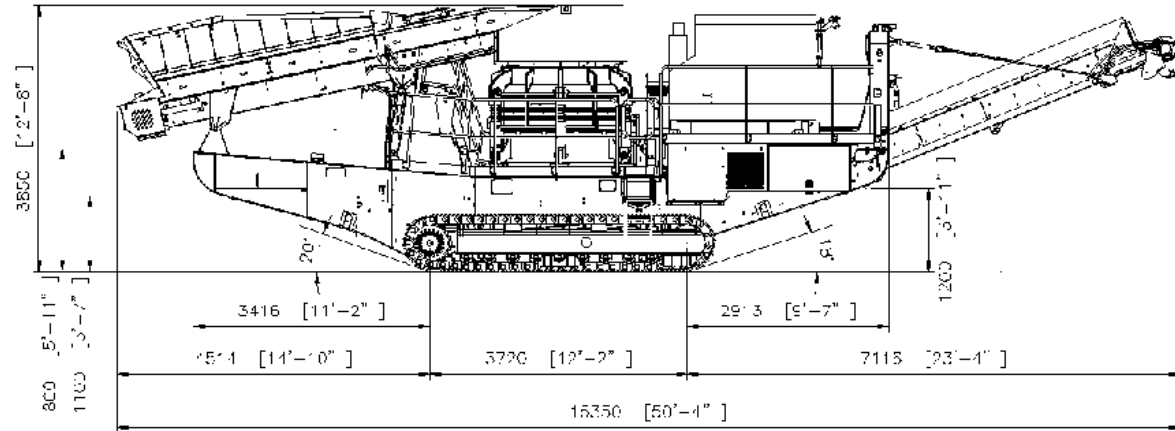



Powerscreen equipment complies with CE requirements.

Please consult Powerscreen if you have any other specific requirements in respect of guarding, noise or vibration levels, dust emissions, or any other factors relevant to health and safety measures or environmental protection needs. On receipt of specific requests, we will endeavour to ascertain the need for additional equipment and, if appropriate, quote extra to contract prices.

All reasonable steps have been taken to ensure the accuracy of this publication, however due to a policy of continual product development we reserve the right to change specifications without notice.

It is the importers' responsibility to check that all equipment supplied complies with local legislation regulatory requirements.

Plant performance figures given in this brochure are for illustration purposes only and will vary depending upon various factors, including feed material gradings and characteristics. Information relating to capacity or performance contained within this publication is not intended to be, nor will be, legally binding.

GET IN TOUCH

Dungannon

200 Coalisland Road, Dungannon,
Co Tyrone, BT71 4DR, Northern Ireland
Tel: +44 (0) 28 87 718 500
Fax: +44 (0) 28 87 747 231

Louisville

11001 Electron Drive,
Louisville, Kentucky, 40299 USA
Tel: +1 502 736 5200
Fax: +1 502 736 5202

