

POWERSCREEN® 1500 MAXTRAK

CONE CRUSHER



TECHNICAL SPECIFICATION - REV 9. 01/01/2019





MAXTRAK 1500



OVERVIEW

SPECIFICATION

Total Weight	89,000kg (196,211bs)
Transport	Length 22m (72' 6")
	Height 3.85m (12' 8")
	Width 3.5m (11' 6")
Working	Length 24.3m (79' 9")
	Height 6.2m (20' 4")
	Width 5.3m (17' 5")
	* Feed conveyor is transported separately
Crusher Type:	1500 Automax Crusher
Power Unit	Caterpillar C-18 ACERT 470 kW (630hp)
Paint Colour	RAL 5021, RAL 7024, RAL 9005

FEATURES & BENEFITS

The Powerscreen® 1500 Maxtrak is one of the largest track mobile cone crusher on the market developed for larger end users producing large volumes of product, such as sub-base & aggregates. The plant can accept an "all in feed" from a primary crusher & has been designed around the Powerscreen® 1500 Automax® cone crusher, renowned for its excellent throughput, cubicity & reduction ratios.

- Output potential of up to 950 tph / 1050 US tph - depending on material type and crusher settings
- Renowned Automax® crusher technology
- Accepts an 'all in feed'
- Excellent product shape on most applications
- High reduction ratio
- Hydraulic crusher setting
- Cone overload protection
- Large feed hopper with folding sides, liners & crash box
- Feed conveyor folds for maintenance, remove for transport
- Metal detector with contaminated material dump facility
- Cone feed box level control to maintain choke feeding
- Fuel efficient direct crusher drive via PLC controlled clutch
- User friendly & intelligent PLC control system
- Heavy duty chassis & track frame
- Electric re-fuelling pump
- Dust suppression system
- Plant lighting
- Remote control via umbilical

APPLICATIONS



Aggregate
Sand & gravel
Blasted rock
River rock



Recycling
C&D waste
Foundry waste



Mining
Processed ores
Processed minerals



MAXTRAK 1500



CONE CRUSHER

CRUSHER OPTIONS

- Crusher type:** 1500 Automax Crusher
- Liners:** Manganese steel alloy mantle & concave
- Standard concave:** Coarse (C)
Autosand (AS) optional
- Lubrication:** Pumped system having a chassis mounted lube tank with airblast cooler
- Adjustment:** Hydraulic setting adjustment, automatic overload release & hydraulic unblocking
- Control:** 2 Operating modes available:
- Autoset Mode: fixed parameters
- Maxset Mode: load sensing, parameters auto adjust & maximise performance
- Concave options:** Extra Coarse (XC)
Coarse (C)
Autosand (AS)
- Eccentric option:** Short throw
- Drive:** Wedge belt drive from engine via clutch

LINER PROFILE	MAXIMUM FEED SIZE	MAXIMUM RECOMMENDED CSS
Coarse	320mm (12.6")	64mm (2.5")
Auto Sand	150mm (6")	30mm (1.18")





MAXTRAK 1500



HOPPER

- Hopper type:** Fixed feed hopper with foldable extension plates
- Hopper length:** 3.3m (10' 10")
- Hopper width:** 2.75m (9')
- Hopper capacity:** Up to 9m³ (11.8 cu. yd.) gross depending on method of feed
- Hopper body:** 12mm thick mild steel hopper, 10mm replaceable wear resistant liners & crash bar to minimise impacts on feed conveyor

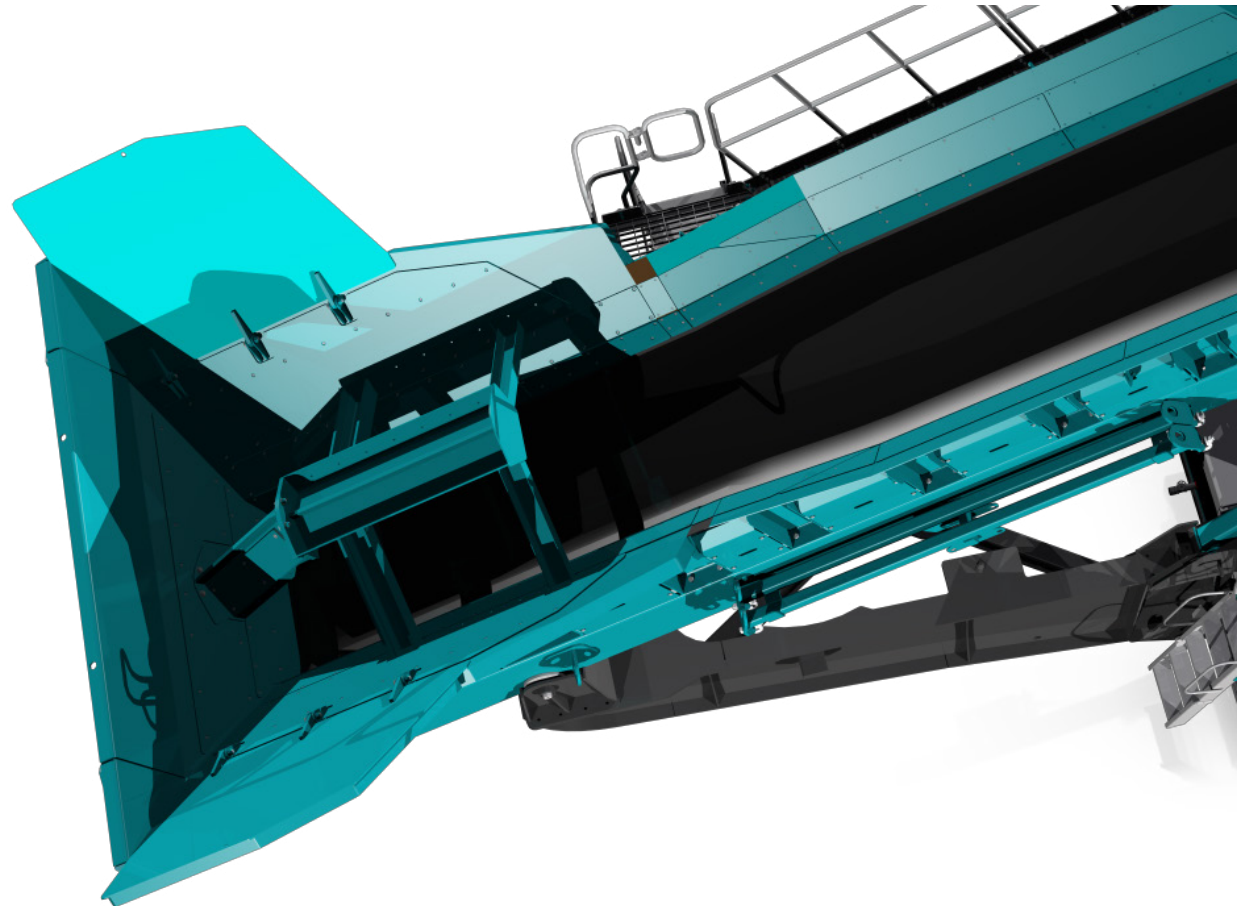



MAXTRAK 1500



FEED CONVEYOR

Conveyor type:	Shallow troughed belt, variable speed
Design:	Can lower horizontally for maintenance & removes for transport
Belt type:	EP1000/5 with 8mm top & 3mm bottom heavy-duty rubber covers, vulcanised joint
Belt adjustment:	Screw adjustment at the tail shaft
Belt width:	1500mm (4' 11")
Feed height:	3.3m (10' 10")
Drive:	Hydraulic motor drive via flange mounted gearbox
Impact rollers:	Below feed hopper

Metal detector:	Suitable for detecting steel & manganese, complete with audible warning device & connected to stop the feed conveyor
Metal purge:	When metal is detected, feed conveyor slides forward & dumps contaminated material down chute reducing risk of metal entering chamber
Lubrication:	Oil lubricated head drum gearbox. Grease nipples for lubrication of shaft bearings.
Level probe:	Crusher feed ring fitted with level probe designed to regulate & constantly choke feed the crusher.

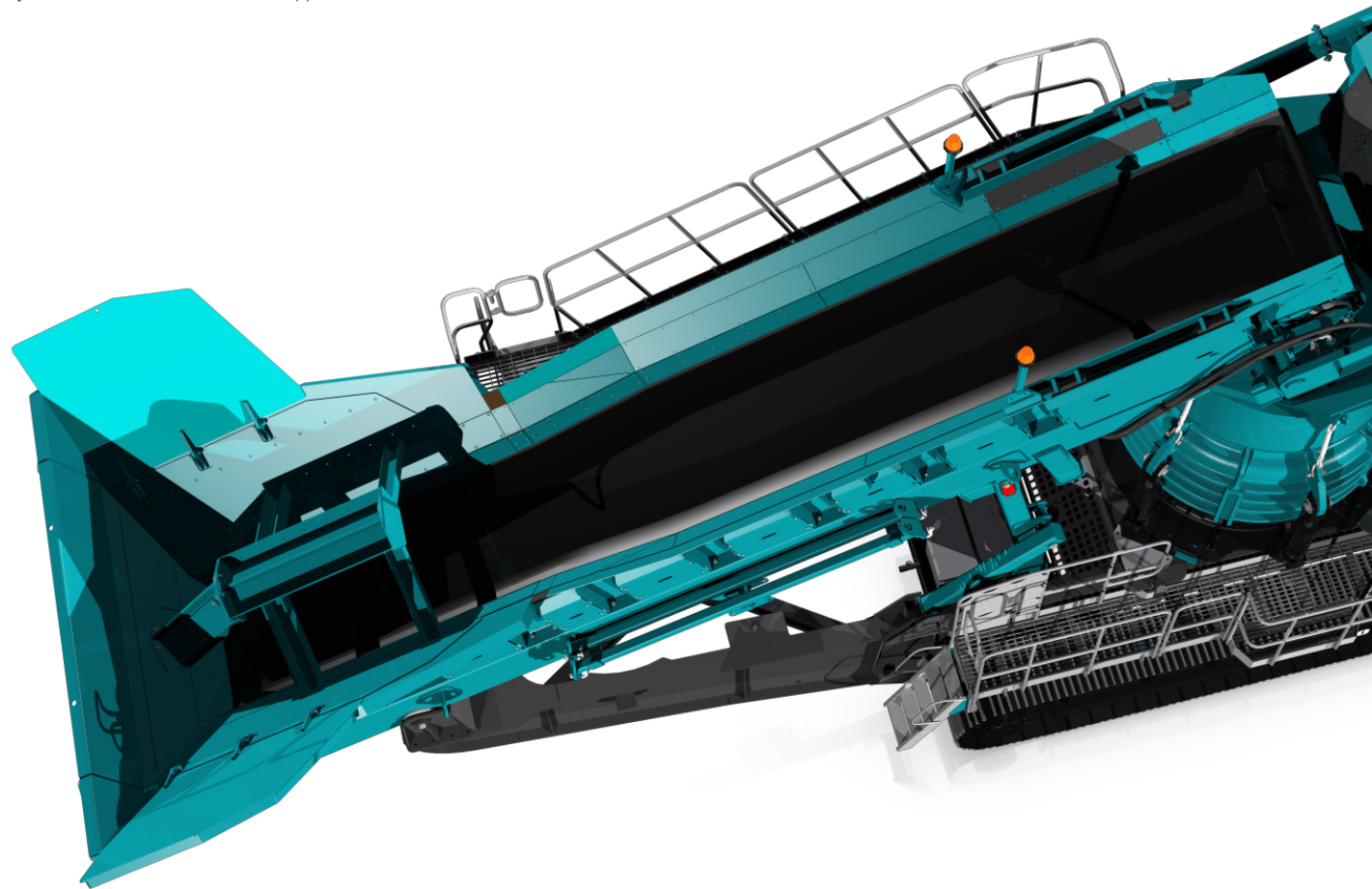



MAXTRAK 1500



↓ PRODUCT CONVEYOR

Conveyor type:	Troughed belt. Fixed speed conveyor with hydraulic drive
Belt type:	EP630/4 with 6mm top / 2mm bottom heavy duty rubber covers & vulcanised joint
Belt width:	1400mm (4' 7")
Discharge height:	4.65m (15' 3")
Stockpile volume:	185m ³ (241 cu. yd.)
Drive:	Direct drive via twin hydraulic motors
Impact bed:	Below the crusher outlet
Belt covers:	Fully enclosed fabricated dust covers with integral head drum guard covers hinge to one side & provide easy access for maintenance.
Belt adjustment:	Screw adjustment at the head drum
Lubrication:	Centralised bank of grease nipples for lubrication of shaft bearings
Speed sensor:	Designed to stop plant feed when discharge conveyor stops

DUST SUPPRESSION SYSTEM

Spray bars with atomiser nozzles are mounted over the product conveyor feed & discharge points & feed conveyor discharge point. Piped to an inlet manifold

Type:	Clean water atomising nozzles
Inlet:	Single point on chassis
Pressure required:	2.8 Bar (42 psi)
Water supply:	24 L/min (6.34G/min) minimum
Frost protection:	Via system drain valves
Pump:	Optional extra

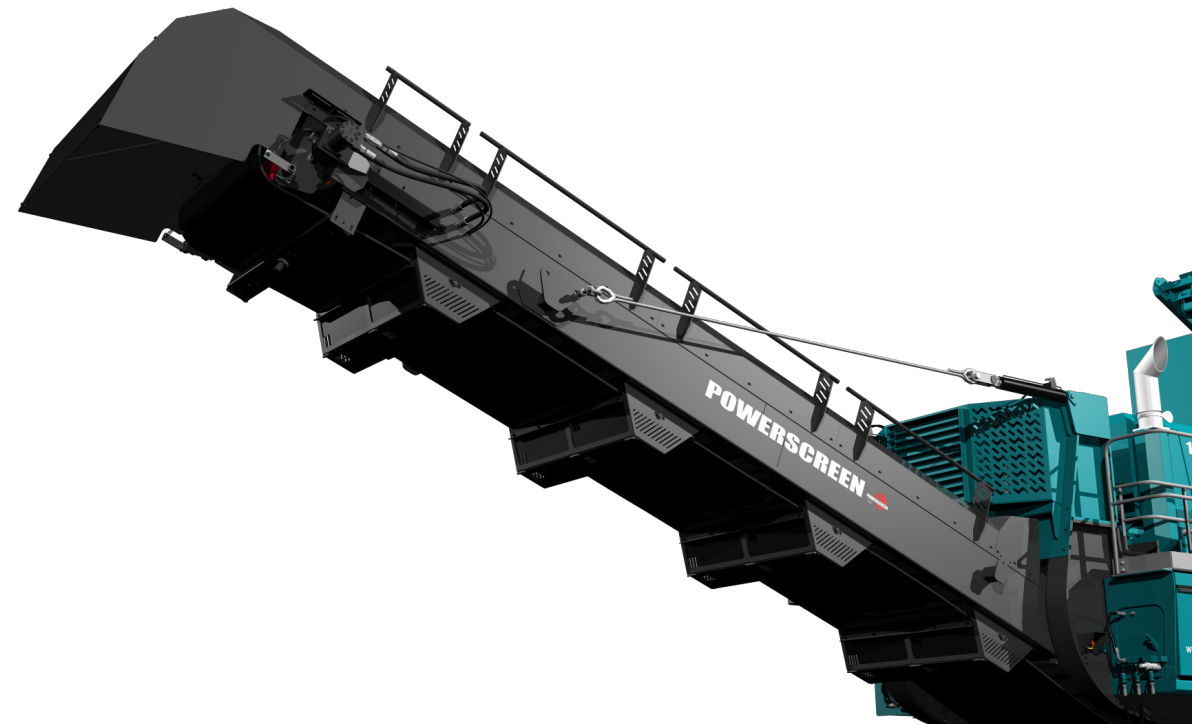



MAXTRAK 1500



POWER UNIT & HYDRAULICS

Tier 3 Equivalent:	Caterpillar C18 ACERT, 470 kW (630hp)
Operating conditions:	Ambient temp. +30°C to -5°C (86°F to 23°F) at altitudes up to 2000m (6562ft) above sea level
- For applications outside this range please consult with Powerscreen as the plant performance / reliability may be affected.	
Operating rpm:	1800rpm
Plant drive:	High quality pumps driven direct from engine or clutch
Fuel tank capacity:	1000 L (264 US Gal)
Hydraulic tank capacity:	540 L (142 US Gal)
Cone lube oil tank capacity:	340 L (90 US Gal)
Clutch type:	Highly efficient, wet plate clutch with electro hydraulic operation & control
Crusher drive:	Direct drive via wedge belts
Service access:	Excellent service accessibility with remote oil, fuel & air filters

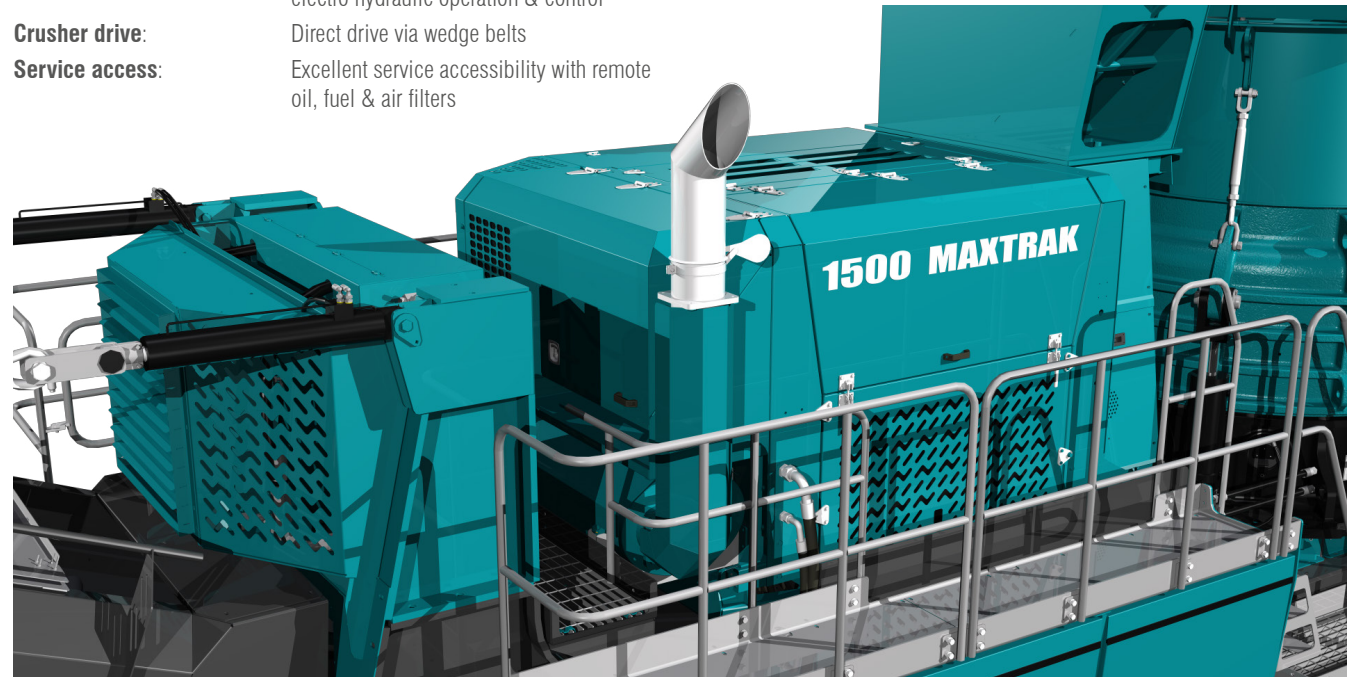



MAXTRAK 1500



↓ TRACKS

Type: Heavy duty, weld on tracks

Sprocket centres: 4800mm (15' 9")

Track width: 600mm (2')

Gradeability: 25 degrees maximum

High speed: 0.7kph (0.44 mph)

Tensioning: Hydraulic adjuster, grease tensioned





MAXTRAK 1500



PLANT CONTROLS & OTHER

CHASSIS

Heavy duty I-Section welded construction, provides maximum strength & accessibility

CHUTES

Feed box: Fabricated in 6mm mild steel plate. Hinge down back plate to lower feed conveyor head section for transportation

Product conveyor: Fabricated in 10mm mild steel plate with replaceable 10mm wear resistant liners at impact points

GUARDS

Wire mesh or sheet metal guards are provided for all drives, pulleys & couplings.

PLATFORMS

Platforms are provided for maintenance on both sides of the cone, one side of the power unit, feed conveyor & product conveyor. All platforms are galvanised as standard & are made from steel flooring with steel toe boards, double row handrails & access ladders.

UMBILICAL CONTROL

An umbilical control unit is also supplied with the plant. This is used to control the tracking function & is also fitted with a stop button for the plant

PLANT CONTROLS

The crusher control is fully integrated into the plant PLC control system. This enables crusher setting changes to be made easily & simply on the fly & also allows the user to calibrate & monitor manganese wear.

- Full PLC control system
- 320 x 240 pixel backlit screen
- Complete pictorial user controls
- Multi-function backlit menu buttons
- High Definition screen
- Full system diagnostics

A navigation wheel is fitted onto the control system to operate all of the plant functions including:

- Engine speed
- Feeder (start/stop/speed)
- Product conveyor (start/stop)
- Cone (start/stop)
- Metal purge sequence
- Crusher control
- Plant diagnostics



MAXTRAK 1500



OPTIONS

RADIO REMOTE CONTROL

Complete with integrated tracking functions & plant stop button. NB - Only available in certain countries where type approval has been obtained.

Remote can also be used to:

- Start/Stop feeder
- Start metal purge sequence

ELECTRIC REFUELLING PUMP

A 24 volt refuelling pump allows fuel to be drawn from a remote source. Fuel transfer rate of 100 L/min (22 G/min)

HYDRAULIC WATER PUMP

A hydraulically powered water pump is available to power the dust suppression system.

OPTIONAL EXTRAS

- Fine concave
- Product conveyor belt weigher
- Crusher mounted camera - displayed on screen beside control panel
- Radio remote control



MAXTRAK 1500



↓ POWERSCREEN PULSE

RECORD, DISPLAY AND ANALYSE DATA:

HIGH EFFICIENCY THROUGH PRECISE INFORMATION

Available online anywhere and at any time: comprehensive information on the GPS location, start and stop times, fuel consumption, tonnages, cone settings, wear ratings, operating hours, maintenance status, and much more.





AVAILABLE ANYWHERE AND AT ANY TIME



DASHBOARD DISPLAY



FLEET OVERVIEW



WEEKLY REPORT DIRECT TO YOUR INBOX



GPS: MACHINE TRACKING



REPORTING UTILISATION, PERFORMANCE & PART SPECIFIC



MAXTRAK 1500



DIMENSIONS

Figure 1: 1500 Maxtrak
Working Position

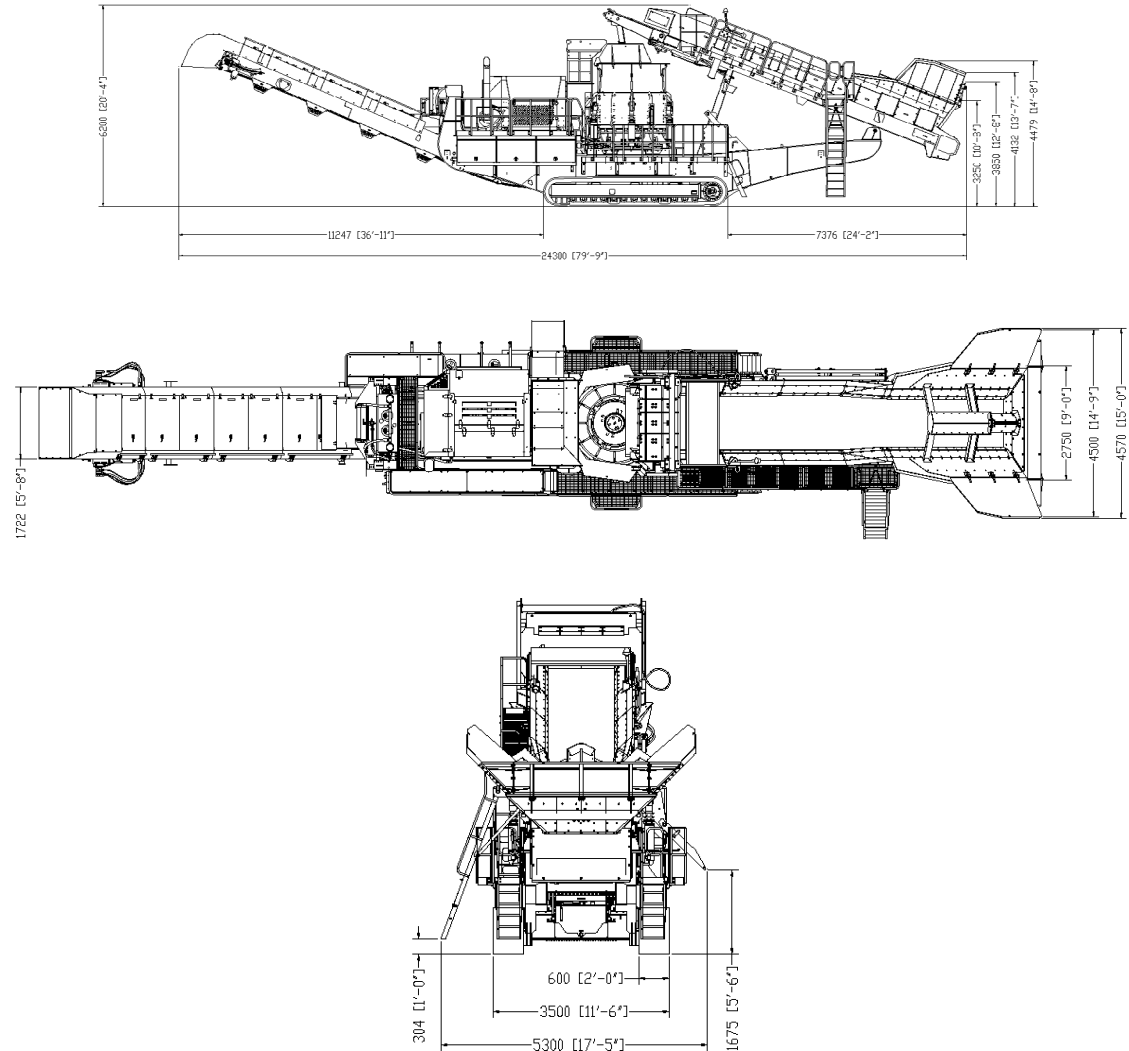

[MORE DIMENSIONS OVERLEAF](#)



MAXTRAK 1500



DIMENSIONS

Figure 2: 1500 Maxtrak
Transport Position

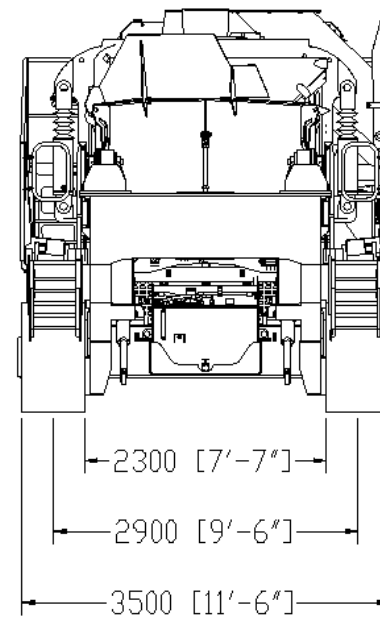
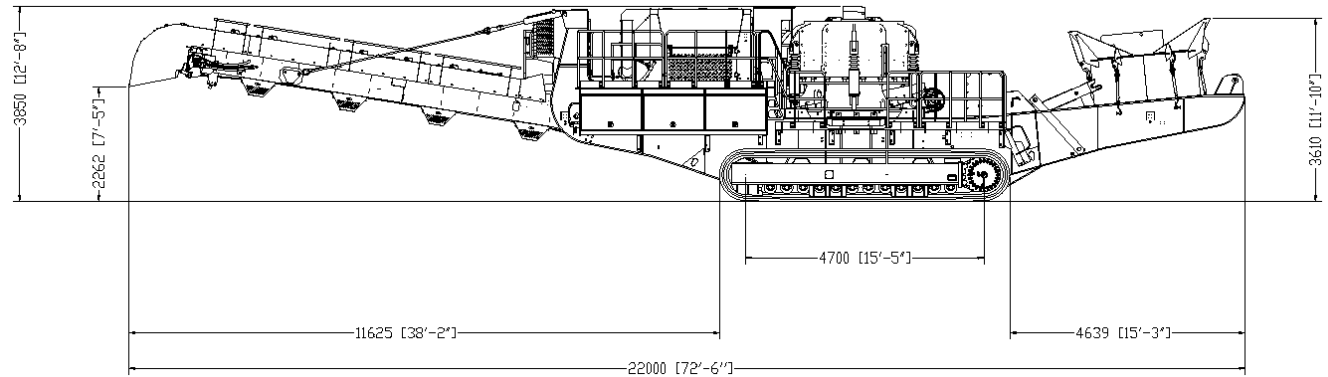

[MORE DIMENSIONS OVERLEAF](#)



MAXTRAK 1500



DIMENSIONS

Figure 3: 1500 Maxtrak
Transport Position

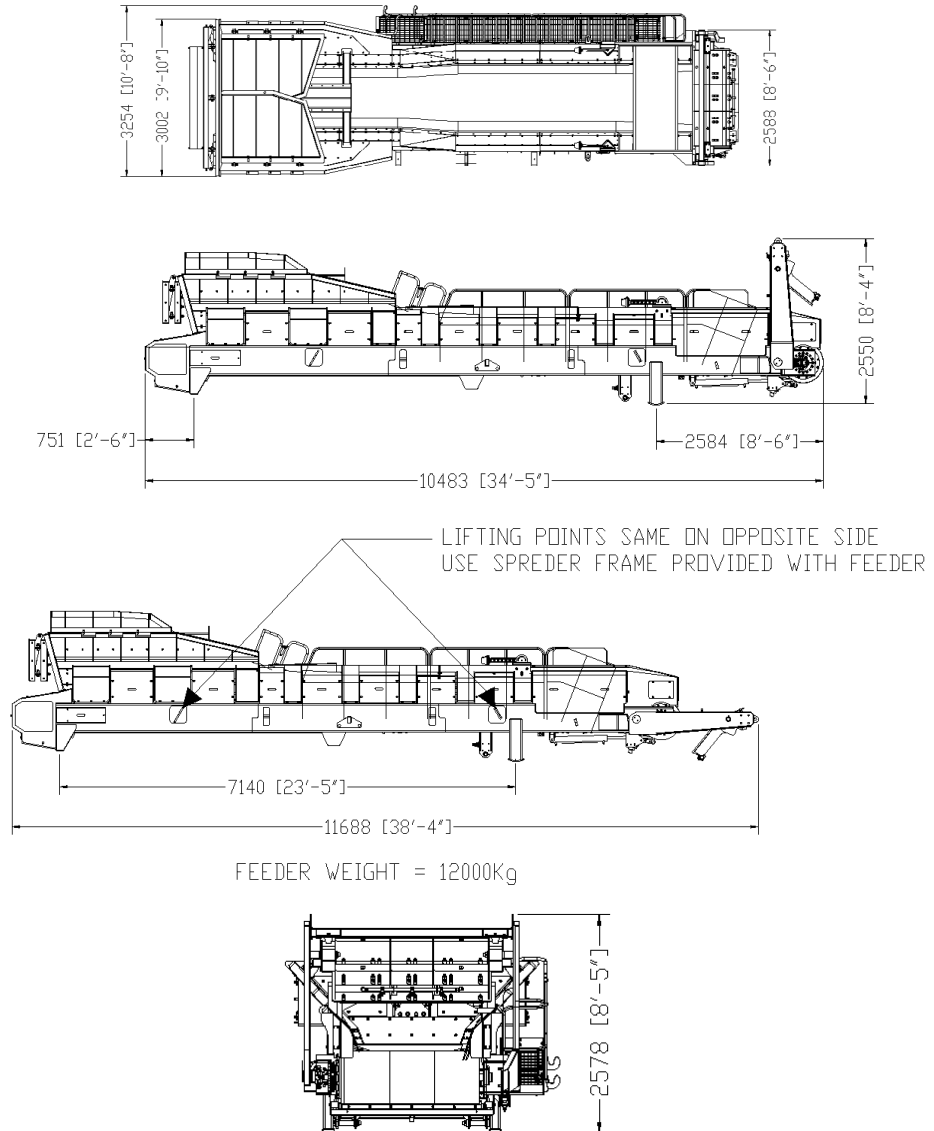



Powerscreen equipment complies with CE requirements.

Please consult Powerscreen if you have any other specific requirements in respect of guarding, noise or vibration levels, dust emissions, or any other factors relevant to health and safety measures or environmental protection needs. On receipt of specific requests, we will endeavour to ascertain the need for additional equipment and, if appropriate, quote extra to contract prices.

All reasonable steps have been taken to ensure the accuracy of this publication, however due to a policy of continual product development we reserve the right to change specifications without notice.

It is the importers' responsibility to check that all equipment supplied complies with local legislation regulatory requirements.

Plant performance figures given in this brochure are for illustration purposes only and will vary depending upon various factors, including feed material gradings and characteristics. Information relating to capacity or performance contained within this publication is not intended to be, nor will be, legally binding.

GET IN TOUCH

Dungannon

200 Coalisland Road, Dungannon,
Co Tyrone, BT71 4DR, Northern Ireland
Tel: +44 (0) 28 87 718 500
Fax: +44 (0) 28 87 747 231

Louisville

11001 Electron Drive,
Louisville, Kentucky, 40299 USA
Tel: +1 502 736 5200
Fax: +1 502 736 5202

